



MOD I42 Ver.02

INPUT & OUTPUT EXPANSION MODULE



Supervisory system

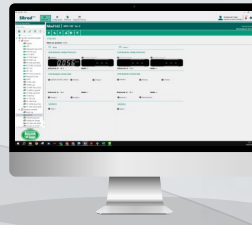

MOD I42/02-05T-17015-2503

Have this manual in the palm of your hand by FG Finder application.

WARNING

BEFORE THE INSTALLATION OF THE CONTROLLER, WE RECOMMEND READING THE INSTRUCTION MANUAL IN FULL TO PREVENT POSSIBLE DAMAGE TO THE PRODUCT

PRODUCT INSTALLATION PRECAUTIONS:
 Before performing any procedure in this instrument, disconnect it from the power grid; Ensure that the instrument has adequate ventilation, avoid installation on control panels containing devices that could cause it to operate outside its specified temperature range; Install the product away from sources that may generate electromagnetic disturbances, such as : motors, contactors, relays , solenoid valves, etc;

AUTHORIZED SERVICE:
 The installation and maintenance of the product must be performed only by qualified personnel;

ACCESSORIES:
 Use only Full Gauge Controls original accessories.
 If you have any questions, please contact our technical support.

THROUGH CONTINUOUS DEVELOPMENT, FULL GAUGE CONTROLS RESERVES THE RIGHT TO CHANGE THE INFORMATION CONTAINED IN THIS MANUAL AT ANY TIME, WITHOUT PRIOR NOTICE.

1. DESCRIPTION

MOD I42 is an input expansion module designed to operate in stand-alone mode (after configuration) or in conjunction with SISTRAD®. It allows the expansion of the capacity of digital events (on/off), and analog temperature values and other values can be measured by any sensor with a 4-20mA output. The conversion resolution of the AIN analog inputs is 3000 points.

The instrument allows the monitoring and signaling of several events and quantities, such as:

- Switches, thermal relays, circuit breakers, digital level sensors, high/low pressure switches;
- NTC temperature sensors;
- 4-20 mA current output sensors.

The software is used to configure the instrument's working parameters, which remains operating in stand-alone mode in case of loss of serial communication, without losing any sensory or control functions.

2. APPLICATIONS

- Sensor monitoring for compressor racks with capacity for up to two racks. Each **MOD I42** accepts up to two compressors;
- Sensors monitoring with 4-20mA output.

3. TECHNICAL SPECIFICATIONS

Power supply	85 ~ 265 Vac
Approximate consumption	6VA
Operating temperature	0 to 50°C / 32 to 122°F
Measurement temperature (**)	-50 to 200°C / -58 to 392°F
Operating humidity	10 to 90%UR (without condensation)
Outputs	OUT1 / OUT2 - 5(3)A/250Vac 1/8HP
12 Vdc - OUT	Non-regulated, used for 4-20mA sensors
Four analog inputs for sensors	Non-insulated 4-20mA analog inputs
Resolution	3000 points
Six digital / analog inputs	Non-insulated digital input (for dry contact) or NTC temperature sensor (*) input
4 digital inputs	Non-insulated digital input (for dry contact)
Product dimensions	115 x 90 x 40mm (WxHxD)

(*) Model SB41 - Full Gauge Controls, sold separately.

(**) This instrument can measure and control temperatures of up to 200°C when used in conjunction with a model Sb59 silicon sensor cable (sold separately).

5. ADJUSTMENT OF THE PARAMETERS

FUN	FUNCTION	CELSIUS (FAHRENHEIT) psi (bar)			
		MÍN	MÁX	UNITS	DEFAULT
F01	G1 - AIN1 - AIN1 Analog input configuration	0	2	-	0
F02	G1 - AIN1 - Unit of measurement	1	68	-	12
F03	G1 - AIN1 - AIN1 number of decimal places	0	3	-	0
F04	G1 - AIN1 - 4mA sensor lower limit	-32768	32767	-	0
F05	G1 - AIN1 - 20mA sensor upper limit	-32768	32767	-	500
F06	G1 - AIN1 - Out-of-range or in-range alarm of AN1 analog input	0	1	-	0
F07	G1 - AIN1 - Alarm validation time of AN1 analog input	no	9999	s	30
F08	G1 - AIN1 - Indication offset	-32768	32767	-	0
F09	G1 - AIN1 - Lower alarm limit of AIN1 analog input	-32768	32767	-	0
F10	G1 - AIN1 - Upper alarm limit of AIN1 analog input	-32768	32767	-	500

IMPORTANT:

Because of the conversion resolution of the AIN analog inputs, it is possible to sample the measured value of the sensor at approximately 3000 points. If the entire measurement scale is larger than the number of points, the displayed value will show jumps.

EXAMPLE:

F14 - G1 - AIN2 – Configuration of the sensor scale beginning at 4mA= 0

F15 - G1 - AIN2 – Configuration of the sensor full scale at 20mA=6000

In this case the measured value will increase approximately by two since the configured scale is twice the resolution of the analog input.

4. WIRING DIAGRAM

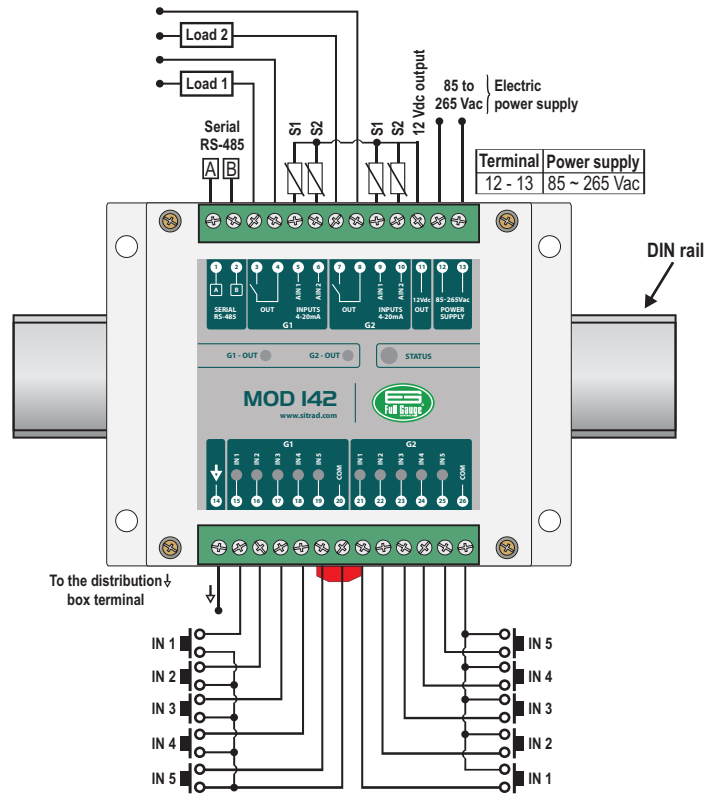

FUN	FUNCTION	CELSIUS (FAHRENHEIT) psi (bar)			
		MÍN	MÁX	UNITS	DEFAULT
F11	G1 - AIN2 - AIN2 analog input configuration	0	2	-	0
F12	G1 - AIN2 - Unit of measurement	1	68	-	12
F13	G1 - AIN2 - AIN1 number of decimal places	0	3	-	0
F14	G1 - AIN2 - 4mA sensor lower limit	-32768	32767	-	0
F15	G1 - AIN2 - 20mA sensor upper limit	-32768	32767	-	500
F16	G1 - AIN2 - Out-of-range or in-range alarm of AN2 analog input	0	1	-	0
F17	G1 - AIN2 -Alarm validation time of AN2 analog input	no	9999	s	30
F18	G1 - AIN2 - Indication offset	-32768	32767	-	0
F19	G1 - AIN2 - Lower alarm limit of AIN2 analog input	-32768	32767	-	0
F20	G1 - AIN2 - Upper alarm limit of AIN2 analog input	-32768	32767	-	500
F21	G1 - IN1 - Input configuration (or NTC temperature sensor)	0	5	-	0
F22	G1 - IN1 - Input in-range or out-of-range temperatura alarm	0	1	-	0
F23	G1 - IN1 - Temperature alarm validation time	no	9999	s	30
F24	G1 - IN1 - Indication time	-5.0(9)	5.0(9)	°C (°F)	0
F25	G1 - IN1 -Input temperature alarm lower limit	-50(-58)	200(392)	°C (°F)	-50/-58
F26	G1 - IN1 - Input temperature alarm upper limit	-50(-58)	200(392)	°C (°F)	200/392
F27	G1 - IN2 - Input configuration (or NTC temperature Sensor)	0	5	-	0
F28	G1 - IN2 - Input in-range or out-of-range temperature alarm	0	1	-	0
F29	G1 - IN2 -Temperature alarm validation time	no	9999	s	30
F30	G1 - IN2 - Indication offset	-5.0(9)	5.0(9)	°C (°F)	0
F31	G1 - IN2 -Input temperature alarm lower limit	-50(-58)	200(392)	°C (°F)	-50/-58
F32	G1 - IN2- Input temperature alarm upper limit	-50(-58)	200(392)	°C (°F)	200/392
F33	G1 - IN3 - Input configuration (or NTC temperature Sensor)	0	5	-	0
F34	G1 - IN3 - Input in-range or out-of-range temperature alarm	0	1	-	0
F35	G1 - IN3 - Temperature alarm validation time	no	9999	-	30
F36	G1 - IN3 - Indication offset	-5.0/-9	5.0/9	°C (°F)	0
F37	G1 - IN3 - Input temperature alarm lower limit	-50/-58	200/392	°C (°F)	-50/-58
F38	G1 - IN3 - Input temperature alarm upper limit	-50/-58	200/392	°C (°F)	200/392
F39	G1 - IN4- Input configuration	0	3	-	0
F40	G1 - IN5 - Input configuration	0	3	-	0
F41	G1 - OUT - Digital output configuration	0	1	-	0
F42	G2 - AIN1 - AIN1 analog input configuration	0	2	-	0
F43	G2 - AIN1- Unit of measurement	1	68	-	12
F44	G2 - AIN1 -AIN1 number of decimal places	0	3	-	0
F45	G2 - AIN1 - 4mA sensor lower limit	-32768	32767	-	0
F46	G2 - AIN1 - 20mA sensor upper limit	-32768	32767	-	500
F47	G2 - AIN1 - Out-of-range or in-range alarm of AN1 analog input	0	1	-	0
F48	G2 - AIN1- Alarm validation time of AN1 analog input	no	9999	s	30
F49	G2 - AIN1 - Indication offset	-32768	32767	-	0
F50	G2 - AIN1 - Lower alarm limit of AIN1 analog limit	-32768	32767	-	0
F51	G2 - AIN1 - Upper alarm limit of AIN1 analog limit	-32768	32767	-	500
F52	G2 - AIN2 -AIN2 analog input configuration	0	2	-	0
F53	G2 - AIN2 -Unit of measurement	1	68	-	12
F54	G2 - AIN2 - AIN1 number of decimal places	0	3	-	0
F55	G2 - AIN2 - 4mA sensor lower limit	-32768	32767	-	0
F56	G2 - AIN2 - 20mA sensor upper limit	-32768	32767	-	500

FUN	FUNCTION	CELSIUS (FAHRENHEIT) psi (bar)			
		MIN	MAX	UNITS	DEFAULT
F57	G2 - AIN2 - Out-of-range or in-range alarm of AN2 analog input	0	1	-	0
F58	G2 - AIN2 - Alarm validation time of AN2 analog input	no	9999	s	30
F59	G2 - AIN2 - Indication offset	-32768	32767	-	0
F60	G2 - AIN2 - Lower alarm limit of AIN2 analog input	-32768	32767	-	0
F61	G2 - AIN2 - Upper alarm limit of AIN2 analog input	-32768	32767	-	500
F62	G2 - IN1 - Input Configuration (or NTC temperature sensor)	0	5	-	0
F63	G2 - IN1 - Input in-range or out-of-range temperature alarm	0	1	-	0
F64	G2 - IN1 - Temperature alarm validation time	no	9999	s	30
F65	G2 - IN1 - Indication offset	-5.0(9)	5.0(9)	°C (°F)	0
F66	G2 - IN1 - Input temperature alarm lower limit	-50(-58)	200/392	°C (°F)	-50/-58
F67	G2 - IN1 - Input temperature alarm upper limit	-50(-58)	200/392	°C (°F)	200/392
F68	G2 - IN2 -Input configuration (or NTC temperature sensor)	0	5	-	0
F69	G2 - IN2 - Input in-range or out-of-range temperature alarm	0	1	-	0
F70	G2 -IN2 - Temperature alarm validation time	no	9999	s	30
F71	G2- IN2 - Indication offset	-5.0/-9	5.0/9	°C (°F)	0
F72	G2 - IN2 - Input temperature alarm lower limit	-50/-58	200/392	°C (°F)	-50/-58
F73	G2 - IN2 - Input temperature alarm upper limit	-50/-58	200/392	°C (°F)	200/392
F74	G2 - IN3 - Input configuration (or NTC temperature sensor)	0	5	-	0
F75	G2 - IN3 - Input in-range or out-of-range temperature alarm	0	1	-	0
F76	G2 - IN3 - Temperature alarm validation time	no	9999	s	30
F77	G2 - IN3 - Indication offset	-5.0/-9	5.0/9	°C (°F)	0
F78	G2 - IN3 - Input temperature alarm lower limit	-50/-58	200/392	°C (°F)	-50/-58
F79	G2 - IN3 - Input temperature alarm upper limit	-50/-58	200/392	°C (°F)	200/392
F80	G2 - IN4 - Input configuration	0	3	-	0
F81	G2 - IN5 - Input configuration	0	3	-	0
F82	G2 - OUT - Digital output configuration	0	1	-	0
F83	Startup delay	no	240	min	no
F84	Address of the instrument in the RS-485 network	1	247	-	201

ATTENTION: If you want to install more than one **MODI42** on the same network, connect the first instrument and change its address (this address will now be unique to this instrument). Connect the second instrument and assign a second address (unique to this instrument), and so on, as many times as required.

Unit of measurement according to the type of sensor used in the AINx analog input as described below:

[0] Not defined	[20] Vac (Volt)	[40] x10 h (Hour multiple of 10)	[60] MW (Megawatt)
[1] °C (Celsius)	[21] Vdc (Volt DC)	[41] kW (Kilowatt)	[61] MVA (Megavolt ampere)
[2] °F (Fahrenheit)	[22] x10 Vac (Volt multiple of 10)	[42] kg/m³ (Kilogram per cubic meter)	[62] kVA (Kilovolt ampere reactive)
[3] K (Kelvin)	[23] Hz (Hertz)	[43] J/kg-K (Joule per kilogram kelvin)	[63] MVA (Megavolt ampere reactive)
[4] atm (Atmosphere)	[24] A (Ampere)	[44] L/h (Liters per hour)	[64] kWh (Kilovolt ampere hour)
[5] bar (bar)	[25] W (Watt)	[45] Reserved (Do not use)	[65] MVAh (Megavolt ampere hour)
[6] mmHg (Millimeter of mercury)	[26] HP (Horse-power)	[46] Reserved (Do not use)	[66] kWh (Kilowatt hour)
[7] cmHg (Centimeter of mercury)	[27] g (Gram)	[47] Reserved (Do not use)	[67] MWh (Megawatt hour)
[8] inHg (Inch of mercury)	[28] kg (Kilogram)	[48] Reserved (Do not use)	[68] Power factor
[9] kg/cm² (Kilogram per square centimeter)	[29] t (Ton)	[49] Reserved (Do not use)	
[10] t/in² (Ton per square inch)	[30] % (Percentage)	[50] Reserved (Do not use)	
[11] Pa (Pascal)	[31] % (First watch bubble levels)	[51] Reserved (Do not use)	
[12] psi (Pounds per square inch)	[32] %UR (First watch humidity)	[52] hh:mm (Hour and minute)	
[13] inH₂O (Inch of water)	[33] ms (Millisecond)	[53] x10 hh:mm (Hour and minute multiple of 10)	
[14] %UR (Humidity)	[34] s (Second)	[54] Var (Volt ampere reactive)	
[15] cm³ (Cubic centimeter)	[35] m (Minute)	[55] VA (Volt ampere)	
[16] in³ (Cubic inch)	[36] h (Hour)	[56] Wh (Watt Hour)	
[17] m³ (Cubic meter)	[37] x10 ms (Millisecond multiple of 10)	[57] VAh (Reactive power)	
[18] l (Liter)	[38] x10 s (Second multiple of 10)	[58] VAh (Volt ampere hour)	
[19] ppm (Part per million)	[39] x10 m (Minute multiple of 10)	[59] kVA (Kilovolt ampere)	

5.1. DESCRIPTION OF THE PARAMETERS

F01 - G1 - AIN1 - AIN1 analog input configuration:

F11 - G1 - AIN2 - AIN2 analog input configuration:

F42 - G2 - AIN1 - AIN1 analog input configuration:

F52 - G2 - AIN2 - AIN2 analog input configuration:

These functions allow disabling or configuring each analog input to act or not act on the digital output as described below:

0 = Input disabled;

1 = Enables the AIN analog input and the alarm activates the output;

2 = Enables the AIN analog input and the alarm does not activate the output;

NOTE: Functions **F01** and **F11** act on output **OUT1**. Functions **F42** and **F52** act on output **OUT2**.

F05 - G1 - AIN1 - 20mA sensor upper limit:

F15 - G1 - AIN2 - 20mA sensor upper limit:

F46 - G2 - AIN1 - 20mA sensor upper limit:

F56 - G2 - AIN2 - 20mA sensor upper limit:

Sets the maximum value measured by the sensor installed in each AIN analog input.

F21 - G1 - IN1 - Input configuration (or NTC temperature sensor):

F27 - G1 - IN2 - Input configuration (or NTC temperature sensor):

F33 - G1 - IN3 - Input configuration (or NTC temperature sensor):

F62 - G2 - IN1 - Input configuration (or NTC temperature sensor):

F68 - G2 - IN2 - Input configuration (or NTC temperature sensor):

F74 - G2 - IN3 - Input configuration (or NTC temperature sensor):

These functions configure the type of each input and the operation mode. As described below:

0 = Configures the input as digital and the alarm activates the digital;

1 = Configures the input as digital and the alarm does not activate the digital output when the contact is closed;

2 = Configures the input as digital and the alarm activates the digital output when the contact is open;

3 = Configures the input as digital and the alarm does not activate the digital output when the contact is open;

4 = Configures the input as analog for NTC pressure sensor, and activates output alarm **OUT1** or **OUT2**;

5 = Configures the input as analog for NTC pressure sensor, and does not activate output **OUT1** or **OUT2**;

NOTE: Functions **F21**, **F27** and **F33** act on output **OUT1**. Functions **F62**, **F68** and **F74** act on output **OUT2**.

F39 - G1 - IN4 - Input configuration:

F40 - G1 - IN5 - Input configuration:

F80 - G2 - IN4 - Input configuration:

F81 - G2 - IN5 - Input configuration:

These functions configure the type of each input and the operation mode. As described below:

0 = Configures the input as digital and the alarm activates the digital output when it is closed;

1 = Configures the input as digital and the alarm does not activate the digital output when the contact is closed;

2 = Configures the input as digital and the alarm activates the digital output when the contact is open;

3 = Configures the input as digital and the alarm does not activate the digital output when the contact is open;

NOTE: Functions **F39** and **F40** act on output **OUT1**. Functions **F80** and **F81** act on output **OUT2**.

F06 - G1 - AIN1 - Out-of-range or in-range alarm of AN1 analog input:

F16 - G1 - AIN2 - Out-of-range or in-range alarm of AN2 analog input:

F47 - G2 - AIN1 - Out-of-range or in-range alarm of AN1 analog input:

F57 - G2 - AIN2 - Out-of-range or in-range alarm of AN2 analog input:

Configures which AIN analog input value range will activate the alarm.

0 = Out-of-range corresponds to the activation of the alarm when the value of the AIN analog input is below the minimum threshold or above the upper threshold.

1 = In-range corresponds to the activation of the alarm when the value of the AIN analog input is above or equal to the minimum threshold and below or equal to the maximum threshold.

F25 - G1 - IN1 - Temperature alarm lower limit:

F31 - G1 - IN2 - Temperature alarm lower limit:

F37 - G1 - IN3 - Temperature alarm lower limit:

F66 - G2 - IN1 - Temperature alarm lower limit:

F72 - G2 - IN2 - Temperature alarm lower limit:

F78 - G2 - IN3 - Temperature alarm lower limit:

This is the reference value to activate the signal indicating the temperature is below the desired point. If this is left at the minimum value the threshold is disabled.

F26 - G1 - IN1 - Temperature alarm upper limit:

F32 - G1 - IN2 - Temperature alarm upper limit:

F38 - G1 - IN3 - Temperature alarm upper limit:

F67 - G2 - IN1 - Temperature alarm upper limit:

F73 - G2 - IN2 - Temperature alarm upper limit:

F79 - G2 - IN3 - Temperature alarm upper limit:

This is the reference value to activate the signal indicating the temperature is above the desired point. If this is left at the maximum value the threshold is disabled.

F02 - G1 - AIN1 - Unit of measurement:

F12 - G1 - AIN2 - Unit of measurement:

F43 - G2 - AIN1 - Unit of measurement:

F53 - G2 - AIN2 - Unit of measurement:

Used to change the unit of measurement according to the type of sensor used in each AIN analog input.

F03 - G1 - AIN1 - AIN1 number of decimal places:

F13 - G1 - AIN2 - AIN1 number of decimal places:

F44 - G2 - AIN1 - AIN1 number of decimal places:

F54 - G2 - AIN2 - AIN1 number of decimal places:

Used to set the number of decimal places of the measured value in each AIN analog input.

F04 - G1 - AIN1 - 4mA sensor lower limit:

F14 - G1 - AIN2 - 4mA sensor lower limit:

F45 - G2 - AIN1 - 4mA sensor lower limit:

F55 - G2 - AIN2 - 4mA sensor lower limit:

Sets the minimum value measured by the sensor installed in each AIN analog input.

F22 - G1 - IN1 - In-range or out-of-range temperature alarm:

F28 - G1 - IN2 - In-range or out-of-range temperature alarm:

F34 - G1 - IN3 - In-range or out-of-range temperature alarm:

F63 - G2 - IN1 - In-range or out-of-range temperature alarm:

F69 - G2 - IN2 - In-range or out-of-range temperature alarm:

F75 - G2 - IN3 - In-range or out-of-range temperature alarm:

Configures the range in which the temperature alarm will act.

0 = Out-of-range corresponds to the activation of the alarm when the temperature is below the minimum threshold or above the upper threshold.

1 = In-range corresponds to the activation of the alarm when the temperature is equal to or above the minimum/maximum threshold.

F07 - G1 - AIN1 - Alarm validation time of AN1 analog input:

F17 - G1 - AIN2 - Alarm validation time of AN2 analog input:

F48 - G2 - AIN1 - Alarm validation time of AN1 analog input:

F58 - G2 - AIN2 - Alarm validation time of AN2 analog input:

F23 - G1 - IN1 - Temperature alarm validation time:

F29 - G1 - IN2 - Temperature alarm validation time:

F35 - G1 - IN3 - Temperature alarm validation time:

F64 - G2 - IN1 - Temperature alarm validation time:

F70 - G2 - IN2 - Temperature alarm validation time:

F76 - G2 - IN3 - Temperature alarm validation time:

This is the time for which the alarm will remain disabled even in temperature alarm conditions. This inhibition time starts to be counted after the startup delay expires.

F08 - G1 - AIN1 - Indication offset:

F18 - G1 - AIN2 - Indication offset:

F49 - G2 - AIN1 - Indication offset:

F59 - G2 - AIN2 - Indication offset:

Sets the minimum value measured by the sensor installed in each AIN analog input.

F24 - G1 - IN1 - Indication offset:

F30 - G1 - IN2 - Indication offset:

F36 - G1 - IN3 - Indication offset:

F65 - G2 - IN1 - Indication offset:

F71 - G2 - IN2 - Indication offset:

F77 - G2 - IN3 - Indication offset:

These functions allow for the compensation of any deviations in the sensor reading.

F09 - G1 - AIN1 - Lower alarm limit of AIN1 analog input:

F19 - G1 - AIN2 - Lower alarm limit of AIN2 analog input:

F50 - G2 - AIN1 - Lower alarm limit of AIN1 analog input:

F60 - G2 - AIN2 - Lower alarm limit of AIN2 analog input:

This is the reference value to activate the signaling when the value measured by the analog input is below the desired point. If this is left at the minimum value the threshold is disabled.

F10 - G1 - AIN1 - Upper alarm limit of AIN1 analog input:

F20 - G1 - AIN2 - Upper alarm limit of AIN2 analog input:

F51 - G2 - AIN1 - Upper alarm limit of AIN1 analog input:

F61 - G2 - AIN2 - Upper alarm limit of AIN2 analog input:

This is the reference value to activate the alarm signal above the desired point. If this is left at the maximum value the threshold is disabled.

F41 - G1 - OUT - Digital output configuration:

F82 - G2 - OUT - Digital output configuration:

Configures how the output will act in case of alarm, NC or NO.

0 = The digital output closes the contact when in alarm condition;

1 = The digital output opens the contact when in alarm condition.

F83 - Startup delay:

Time counted from instrument power up for which any alarm status is disregarded, independently from the state of the digital inputs, temperature inputs, or other AIN analog inputs. After this time has elapsed the instrument starts its normal operation observing the alarm validation times.

F84 - Address of the instrument in the RS-485 network:

This is the instrument's network address for communicating with SITRAD® software (primary Rs485 network)

NOTE: There should be no instruments with the same address in the same network (installation).

6. SIGNALING

COLOR	LED (OUT 1 / OUT2)	LED (INPUTS)	LED (STATUS)	DESCRIPTION
White	—	—	Flashing	Instrument not programmed
Red	—	—	On	Instrument in operation
Blue	—	—	Flashing	Sensor disconnected or damaged
Green	—	—	Flashing	Instrument not calibrated Contact Full Gauge Controls
Green	On	—	—	Output activated
Green	—	—	—	Input in operation
Green	—	Flashing	—	Temperature sensor disconnected or damaged

INTEGRATING CONTROLLERS, RS-485 SERIAL INTERFACE AND COMPUTER.

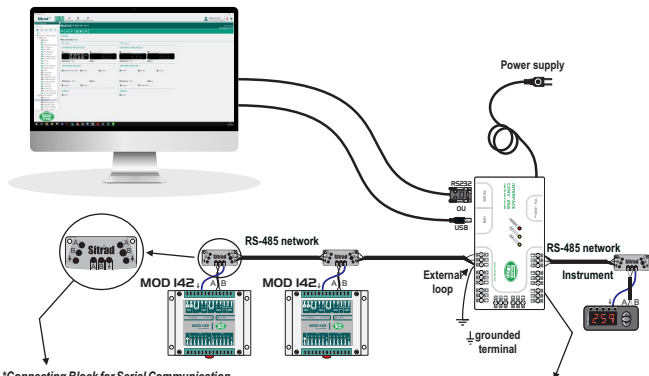

***Connecting Block for Serial Communication**

It is used to interconnect more than one instrument to the Interface. The wires must be connected as follows: Terminal A of the instrument connects to the terminal A of the connection block, which in turn must be connected to terminal A of the Interface. Repeat the procedure for terminals B and \pm , with \pm being the cable mesh (optional ground). The terminal \pm of the connection block must be connected to the respective terminals \pm of each instrument.

RS-485 Serial Interface

Device used to establish the connection of Full Gauge Controls instruments with SITRAD®.

*Sold separately

IMPORTANT

According to chapters of NBR 5410 standard:

- 1: Install surge protectors on the power line;
- 2: Serial communication sensor cables can be installed together but not in the same conduit where power supply and load drive cables are installed.
- 3: Install transient suppressors (RC filter) in parallel with the loads as a way to increase the service life of the relays.

Schematic to connect suppressors in contactors

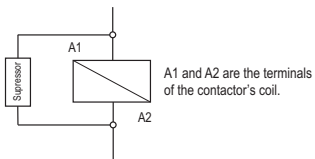

A1 and A2 are the terminals of the contactor's coil.

Schematic to connect suppressors in direct drive loads

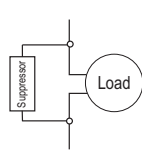

For the direct drive, consider the maximum specified current.

These suppressors are for sale from Full Gauge Controls



ENVIRONMENTAL INFORMATION

PACKAGING:

Materials used in the packaging of the Full Gauge Controls products are 100% recyclable. Be sure to dispose of them using specialized recycling facilities.

PRODUCT:

The components used in the Full Gauge Controls controllers may be recycled and reused if disassembled by specialized companies.

DISPOSAL:

Do not incinerate or dispose of the controllers that have reached the end of their service life in household waste. Be sure to comply with the existing legislation in your area relating to disposal of electronic waste. In case of doubt, please contact Full Gauge Controls.

WARRANTY - FULL GAUGE CONTROLS

Products manufactured by Full Gauge Controls, as of May 2005, have a ten (10) - year warranty directly with the factory and one (1) year before the reseller network, counted from the date of purchase as stated on the invoice. After this said year before the reseller network, the warranty shall continue to be valid if the instrument is sent directly to Full Gauge Controls. The products are warranted in case of defects in workmanship making them unsuitable or inadequate for the intended applications. The warranty is limited to maintenance of instruments manufactured by Full Gauge Controls, disregarding other kinds of expenses, such as indemnity for damages caused to other equipment.

EXCEPTIONS TO WARRANTY

The Warranty does not cover expenses incurred for freight and/or insurance for sending the products with signs of defect or malfunctioning to the provider of technical support services. The following events are also excluded from the warranty: natural wear and tear of parts, external damages caused by falls or inadequate packaging of products.

INVALIDATION OF WARRANTY

- The product warranty shall lose validity, automatically, if:
- The instructions for use and assembly contained in the technical description and the installation procedures described in Standard NBR5410 are not followed;
 - The product is submitted to conditions beyond the limits specified in its technical description;
 - The product is violated or repaired by a person not pertaining to the technical team of Full Gauge;
 - The damages are due to a fall, blow and/or impact, water damage, overload and/or atmospheric discharge.

USE OF WARRANTY

For using the warranty, the customer should send the adequately packaged product, along with the respective invoice to Full Gauge Controls. The customer will bear the freight cost for shipment of the products. Also, as much information as possible with regard to the observed defect should be sent, in order to facilitate the analysis, the testing and the performance of the service.

These processes and any product maintenance shall only be performed by the Technical Support Services of Full Gauge Controls, at the Company headquarters - Rua Júlio de Castilhos, 250 - CEP 92120-030 - Canoas - Rio Grande do Sul - Brazil

© Copyright 2018 • Full Gauge Controls ® • All rights reserved.