



# MT-516EVT *plus* Ver.07

TEMPERATURE CONTROLLER WITH CYCLIC  
TIMER AND VOLTAGE MONITOR

- Alarm
- Buzzer
- Cyclic Timer
- Functions Lockdown
- Control Functions Shutdown
- Sitrad Supervisory system
- Serial programming
- IP 65 FRONT Protection level



MT516EVTPLUSV07-03T-16324-2604

Have this manual in the palm of your hand by FG Finder application.

## 1. DESCRIPTION

Temperature controller for cooling or heating applications. It has a cyclic timer output that can also be configured as an alarm output or as a second stage of cooling or heating. Through the True-RMS voltage meter, it is able to protect the components of the application against undue stresses, whether high or low. In addition, it has internal buzzer, configurable digital filter and an intelligent function blocking system, preventing unauthorized persons from changing the control parameters. The instrument has serial communication for connection to Sitrad.

## 2. SAFETY RECOMMENDATIONS

- Check the controller for correct assembling;
- Make sure that the power supply is off and that it is not turned on during the controller installation;
- Read the present manual before installing and using the controller;
- Use adequate Personal Protective Equipment (PPE);
- For application at sites subject to water spills, such as refrigerated cabinets, install the protecting vinyl supplied with the controller;
- For protection under more critical conditions, we recommend the Ecase cover, which we make available as an optional item (sold separately);
- The installation procedures should be performed by a qualified technician.

## 3. APPLICATIONS

- Milk cooling tanks
- Refrigerated counters
- Air conditioning with automatic winter/summer system

## 4. TECHNICAL SPECIFICATIONS

Power supply	MT-516E: 115 or 230 Vac ±10% (*) (50/60 Hz)
Approximate consumption	2,5VA
Control temperature	-50 to 200°C (-58 to 392°F) (**)
Operating temperature	0 to 50 °C / 32 to 122°F
Maximum output current	OUT1: 16(8)A / 240Vac 1HP OUT2: 16(8)A / 240Vac 1HP
Operating humidity	10 to 90% RH (without condensation)
Dimensions (mm)	76 x 34 x 77 mm (WxHxD)
Cutout dimensions (mm)	71 ± 0,5 x 29 ± 0,5 mm

\*) Admissible variation in relation to the voltage rating.  
 \*\*) This device can measure and control temperatures of up to 200° C when used in conjunction with a model SB59 silicon sensor cable (sold separately).  
 Note: Sensor cable length can be increased to up to 200 meters by the user by using a PP 2 x 24 AWG cable.

## 5. INDICATIONS AND KEYS

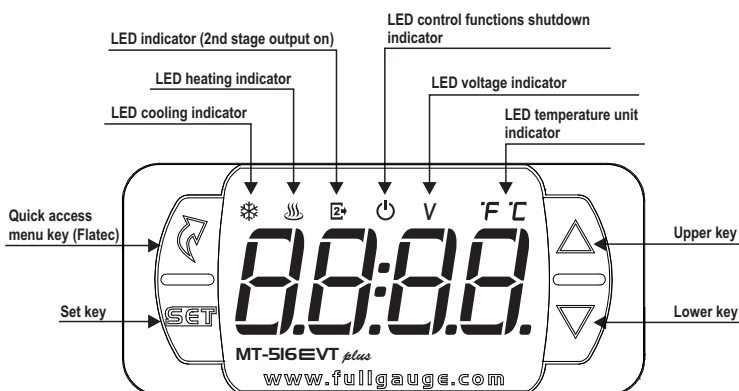

## 6. WIRING DIAGRAM

**IMPORTANT**  
 THE USE OF APPROPRIATE TOOLS IS ESSENTIAL TO AVOID DAMAGE IN THE CONNECTION AT INSTRUMENT TERMINALS:  
 ⊖ SCREWDRIVER SLOT 3/32" (2.4mm) FOR ADJUSTMENTS IN THE SIGNAL TERMINALS;  
 ⊕ SCREWDRIVER PHILLIPS #1 FOR ADJUSTMENTS IN THE POWER TERMINALS;

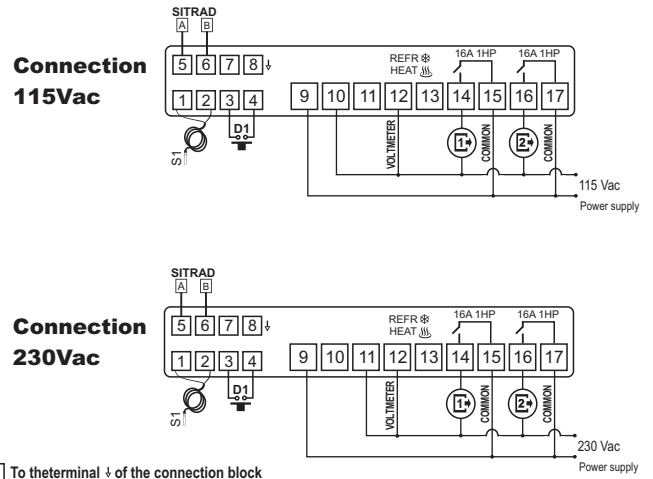

↓ To terminal ↓ of the connection block

### Electrical noise suppression filter

Wiring diagram of suppressors in contactors

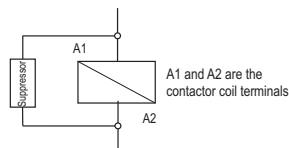

A1 and A2 are the contactor coil terminals.

Wiring diagram of suppressors in direct drive loads

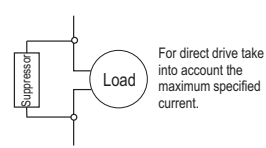

For direct drive take into account the maximum specified current.



### 6.1. Recommendations of IEC60364 standard



- a) Install overload protectors in the controller supply.
- b) Install transient suppressors – suppressor filter RC – in the circuit to increase the service life of the controller relay.
- c) The sensor cables may be together, but not in the same conduit where the power supply of the controller and/or of the loads passes through.

## 7. ASSEMBLING PROCEDURE

- a) Cut out the panel plate where the controller shall be fastened, with sizes X = 71±0.5 mm and Y = 29±0.5 mm;
  - b) Remove side locks : to do that, compress the central elliptical part (with the Full Gauge Controls logo) and displace the locks backwards;
  - c) Introduce the controller in the notch made on the panel, inwards;
  - d) Place the locks again and then displace them until they compress into the panel, fastening the controller to the housing ;
  - e) Perform the electric installation as described in item 6;
  - f) Adjust the parameters as described in item 8.
- ATTENTION:** for installations requiring liquid tight sealing, the notch sizes for the controller installation should be no more than 70.5x29mm. The side locks should be fastened so that they press the sealing rubber avoiding infiltration between the notch and the controller.
- Protector vinyl!**  
 This adhesive vinyl is supplied with the instrument in the package.
- IMPORTANT:** Make the application only after completing the electrical connections.
- a) Retreat the side locks;
  - b) Remove the protective film from the adhesive vinyl face;
  - c) Apply the vinyl over the entire upper part, bending the flaps, as indicated by the arrows - Image VII (item 12);
  - d) Reinstall the locks.
- NOTE:** The vinyl is transparent, allowing visualization of the wiring system of the instrument.

## 8. OPERATIONS





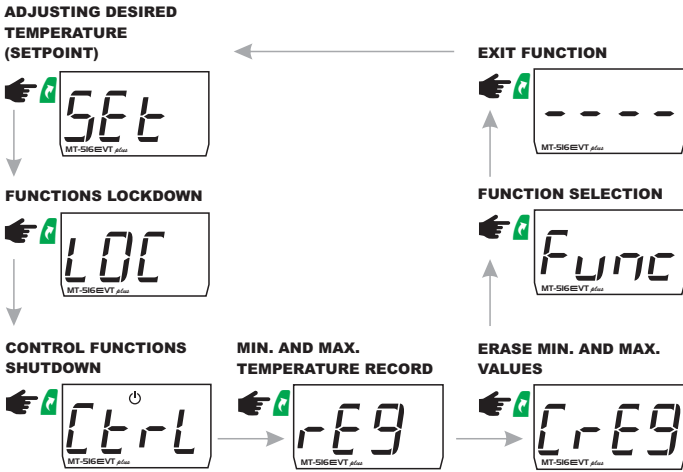



### 8.1. Quick Access Menu Map

To access or browse in the quick access menu, use the  key (quick touch) while the temperature is being displayed by the controller. Each touch displays the next function in the list; to confirm, use the  key (quick touch). For further details, refer to chapter 8.3. See below the functions map













### 8.2. Quick access keys map

When controller is on temperature display mode, the following keys can be used as a shortcut for the following functions:

	Hold down for 2 seconds: setpoint adjustment and cyclic timer (F08=2).
	Hold down for 2 seconds: inhibit audible alarm.
	Hold down for 4 seconds: reverses cyclic timer status.
	Quick touch: minimum and maximum temperature display.
	Press for 2 seconds: when displaying records, clear history.
	Quick touch: displays other measurements.
	Enters quick access menu.
	Press for 5 seconds: switch off control functions
	Enters function selection.







### 8.3. Basic operations

#### 8.3.1. Adjusting desired temperature (setpoint) and cyclic timer times



Hold down the  key for 2 seconds to enter the setpoint adjustment menu. The message  will be shown in the display and then the value to adjust the 1st stage setpoint. Use the  or  keys to change the value and press  to confirm. If the 2nd stage is set as thermostat (F08 = 0 or 1), then the  message will be displayed, indicating the setting of the 2nd stage setpoint. Again use the  or  keys to modify the value, then confirm by pressing . If the 2nd stage is set as cyclic timer (F08=2) it will be possible to set the time on  and the time off .

#### 8.3.2. Functions Lockdown







Using the functions lockdown option ensures greater security whilst operating the device. When it is active, the setpoint and other parameters may be visible to the user, but are protected against undue changes (F25=2). Alternatively, you can block the changes in the control functions by releasing the setpoint setup (F25=1), time ON and time OFF of the cyclic timer.

Using the  key (quick touch), access the  function in the quick access menu, confirm by pressing  (quick touch), then the message  will be displayed. After that, hold down the  key for the time configured for the functions lock (F26), until  is displayed. Upon releasing the key, the message  will be displayed indicating that the block function has been activated.





To unlock, turn off the controller then turn it back on whilst holding down the  key. Keep holding down the key until the message  appears. Keep the key held down for ten seconds and the message  will be shown on the display, indicating the deactivation of the block function once the key is released.

#### 8.3.3. Control Functions Shutdown

Turning off the control functions allows the controller to operate only as temperature gauge, keeping the control outputs and the alarms off. The use of this feature is enable or not by the function of the controls functions . When enable, the control and alarm functions are turned off () or on () via the easy menu in the  option. When the control functions are switched off, the message  will be displayed in alternation with the temperature and other messages. Except when  equals 3 or 4, in these cases the display turns off, keeping only the icon .

**NOTE:** You can also switch the control functions on  off by pressing the key for 5 seconds.



**NOTE:** When switching the control functions back on, MT-SIGEVIT plus will continue to adhere to the same functions "  - Delay to turn on the 1st stage output on" and "  - Delay to turn on the 2nd stage output".

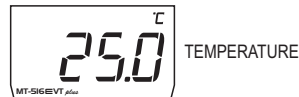

#### 8.3.4. View other measurements

By pressing the  key (quick touch) it is possible to display the voltage and frequency of mains and when the 2nd stage is set as a cyclic timer (F08 = 2), the elapsed time in the cyclic timer can be displayed.









**NOTE:** If a measurement is not available (voltage monitoring disabled, for example) or is the preferred display measurement, it will not be displayed.



#### 8.3.5. Manually changing the cyclic timer status

When the 2nd stage is set as cyclic timer (F08=2), pressing the  key for 4 seconds allows you to manually change the cyclic timer output status from "on" to "off" and vice-versa, independent of the time elapsed. Changing the cyclic timer status will display the message .









#### 8.3.6. Minimum and Maximum Temperature Record

By pressing down the  key or via the quick access menu, the message  appears, after which the minimum and maximum temperatures recorded will be displayed. To erase the current minimum and maximum values, hold down the  key (quick touch) until the message  appears and confirm using the  key.

**Note:** If the  key is pressed while the logs are displayed, the values are reset and the message  is displayed.

**Note:** The maximum and minimum temperatures will only be recorded if the setpoint of one of the stages is reached at least once. Before that, the  message will be displayed for the records of minimum temperature and  for the records of maximum temperature.













#### 8.3.7. Unit Selection



To select the unit in which the device will operate, enter the function  using the access code . Then, press the  key. After this, select the unit desired  or  using the  or  keys; to confirm press . Every time the unit is changed, the functions settings return to the default value, thus, they must be set up again.

#### 8.3.8. Buzzer inhibition

When activated, the buzzer can be inhibited by pressing the  key for two seconds.

### 8.4. Advanced operations

The functions menu can be accessed through the quick access menu, using the  option or by simultaneously pressing the  and  keys whilst the temperature is being displayed. To allow the parameters to be changed, enter  by pressing  (quick touch) and using the  or  keys enter code 123 (one hundred and twenty-three), and then confirm with . To change the other functions, browse the menu using the  or  keys and proceed the same way to adjust them. To exit the menu and return to the normal operation display, press  (long touch) until .

**NOTE:** If the functions lock is enabled, when pressing the  or  keys, the controller will display the message  and will not allow parameter adjustment.

## 8.5. Parameters table

Fun	Description	CELSIUS				FAHRENHEIT			
		Min	Max	Unit	Standard	Min	Max	Unit	Standard
F01	Access code:123 (one hundred and twenty three)	0	999	-	0	0	999	-	0
F02	Sensor indication displacement (offset)	-5.0	5.0	°C	0.0	-9	9	°F	0
F03	1st stage operation mode	0-cool.	1-heat.	-	0-cool.	0-cool.	1-heat.	-	0-cool.
F04	Minimum setpoint allowed to end user (1st stage)	-50	200	°C	2.0	-58	392	°F	35
F05	Maximum setpoint allowed to end user (1st stage)	-50	200	°C	5.0	-58	392	°F	41
F06	1st stage control differential (Hysteresis)	0.1	20.0	°C	1.0	1	36	°F	1
F07	Delay to turn the 1st stage output on	0(no)	999	sec.	180	0	999	sec.	180
F08	2nd stage operation mode	0	4	-	2	0	4	-	2
F09	Cyclic timer/alarm time base	0	3	-	3	0	3	-	3
F10	Cyclic timer/alarm on time	1	999	sec./min.	5	1	999	sec./min.	5
F11	Cyclic timer/alarm off time	0	999	sec./min.	15	0	999	sec./min.	15
F12	Initial cyclic timer status	off	on	-	on	off	on	-	on
F13	Cyclic timer always on while OUT1 output is on	no	yes	-	yes	no	yes	-	yes
F14	Minimum temperature to turn the cyclic timer off	-50	200	°C	0	-58	392	°F	32
F15	Min. allowed setpoint/Low temp. alarm (2nd stage)	-50	200	°C	-50	-58	392	°F	-58
F16	Max. allowed setpoint/High temp. alarm (2nd stage)	-50	200	°C	105	-58	392	°F	221
F17	2nd stage control differential (Hysteresis)	0.1	20.0	°C	1.0	1	36	°F	1
F18	Delay to turn on the 2nd stage output	0(no)	999	sec.	0(no)	0(no)	999	sec.	0(no)
F19	Alarm inhibition time when connecting the controller	0(no)	999	min.	0(no)	0(no)	999	min.	0(no)
F20	Enable Buzzer (0-Disabled / 1-Enabled)	off	on	-	off	off	on	-	off
F21	Status of outputs with damaged sensor	0	2	-	0	0	2	-	0
F22	Output-on time in the event of error	1	999	min.	15	1	999	min.	15
F23	Output-off time in the event of error	1	999	min.	15	1	999	min.	15
F24	Minimum working voltage limit (protection)	90	300	Volts	195	90	300	Volts	195
F25	Maximum working voltage limit (protection)	90	300	Volts	260	90	300	Volts	260
F26	Time for voltage validation for band	1	30	sec.	10	1	30	sec.	10
F27	Voltage offset	-50	60	Volts	0	-50	60	Volts	0
F28	Preferred indication	0	2	-	0	0	2	-	0
F30	Operating mode of the digital input	0	6	-	0	0	6	-	0
F29	Digital filter intensity applied to the sensor	0	9	-	0	0	9	-	0
F31	Functions lockdown	0	2	-	0	0	2	-	0
F32	Time for functions lockdown	15	60	sec.	15	15	60	sec.	15
F33	Control functions shutdown	0(no)	2	-	0(no)	0(no)	2	-	0(no)
F34	Address of the instrument on the RS-485 network	1	247	-	1	1	247	-	1

### 8.5.1. Description of parameters

#### F01 - Access code 123 (one hundred and twenty-three):

This is required to change the configuration parameters. Entering this code is not required to see the adjusted parameters.

It allows you to enter the following access codes:

[123] - Allows you access for changing the table parameters

[231] - Allows you to configure the unit of measurement [°F] or [°C]

#### F02 - Sensor indication displacement (offset):

Enables compensation for any temperature deviations resulting from sensor replacement or change in the cable length.

#### F03 - 1st stage operation mode:

Selects the 1st stage operation mode (OUT1):

[0] - Cooling

[1] - Heating

#### F04 - Minimum setpoint allowed to end user (1st stage):

Prevents accidental setting of extremely low setpoint temperatures.

#### F05 - Maximum setpoint allowed to end user (1st stage):

Prevents accidental setting of extremely high setpoint temperatures.

#### F06 - 1st stage control differential (Hysteresis):

Difference in temperature (hysteresis) between turning the refrigeration (or heating) ON and OFF.

**Example:** You want to control the temperature at 4.0 °C with a differential of 1.0 °C. Therefore, the refrigeration will be turned off at 4.0 °C and turned on again at 5.0 °C (4.0 + 1.0). In the heating mode the output goes off at 4°C and turns on again at 3° (4.0-1.0), according to graphs below:

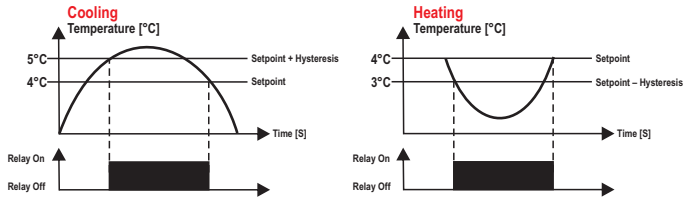

#### F07 - Delay to turn the 1st stage output on:

The minimum time during which the 1st stage output remains off, i.e., the time interval between the last stop and the next start. It relieves the discharge pressure and increases the service life time of the compressor. This delay also occurs when starting up the device. In facilities with several equipment units, assigning different values to the delay time at the start up of each device will allow for demand peaks to be avoided when the devices are activated at different times.

This function can be turned off by setting it at the minimum value 0 [no].

#### F08 - 2nd stage operation mode:

Selects the 2nd stage operation mode:

[0] - Cooling

[1] - Heating

[2] - Cyclic timer

[3] - Absolute extra-range alarm: Considers the values defined in [F15] and [F16] as minimum and maximum values to activate the alarm output.

[4] - Extra-range alarm relating to the 1st stage setpoint: Considers the 1st stage setpoint and the absolute values defined in [F15] and [F16], i.e., the positive value of these functions as minimum and maximum values to activate the alarm output. Limits: [SP1] - [F15] and [SP1] + [F16].

#### F09 - Cyclic timer/alarm time base (F08=2, 3 or 4):

Allows setting of the time bases to turn the OUT 2 output on and off when the 2nd stage is set in cyclic timer or alarm modes. The possible settings for output time on and output time off are, respectively:

[0] - Seconds/Seconds

[1] - Seconds/Minutes

[2] - Minutes/Seconds

[3] - Minutes/Minutes

#### F10 - Cyclic timer/alarm on time (F08=2, 3 or 4):

Allows setting of time the controller remains with OUT 2 output on when the 2nd stage is set in cyclic timer or alarm modes.

#### F11 - Cyclic timer/alarm off time (F08=2, 3 or 4):

Allows setting of time the controller remains with OUT 2 output off when the 2nd stage is set in cyclic timer or alarm modes.

#### F12 - Initial cyclic timer status (F08=2):

Allows you to choose whether the cyclic timer starts on or off.

[0n] - Connected

[0F] - Disconnected

**NOTE:** The OUT 2 output will take this status whenever the cyclic timer resumes operation.

**Example:** By the end of delay to turn the 2nd stage output (F18) on, when exceeding the value set in F14 or exiting the cyclic timer status on while OUT1 output is on (F08=2).

#### F13 - Cyclic timer always on while OUT1 output is on (F08=2):

Keeps OUT2 output always on while OUT 1 output is on. This is recommended for milk coolers, where the cyclic timer commands the stirrer, which remains activated while cooling is activated.

[no] - Stand-alone cyclic timer

[YES] - Cyclic timer always on while OUT1 output is on. When OUT1 output is off the timer will cycle according to times set in F10 and F11.

#### F14 - Minimum temperature to turn the cyclic timer off (F08=2):

This is the minimum temperature in which the cyclic timer will work; below this limit, the cyclic timer is turned off. It is recommended for milk coolers, to allow the stirrer to operate without excessive load, thus avoiding the engine burning out.

**NOTE:** Function F14 has priority over F13.

#### F15 - Minimum allowed setpoint/Low temperature alarm (2nd stage):

#### F16 - Maximum allowed setpoint/High temperature alarm (2nd stage):

When the 2nd stage is defined as thermostat (F08 = 0 or 1), these are the electronic limits. The purpose of this is to avoid unintentional regulation of extremely high or low setpoint temperatures. When the 2nd stage is defined as alarm (F08 = 3 or 4), these are the electronic limits of low [FLLD] and high [FELD] temperatures, respectively. The differential for turning off the alarm is set at 0.1°C/1°F.

For safety reasons, the 1st stage output will switch off if a high temperature alarm [FELD] is activated when configured for heating, or if a low temperature alarm [FLLD] is activated when configured for cooling. For this reason, you must configure the alarm threshold above (if heating) or below (if cooling) the desired temperature (setpoint of the 1st stage).

#### F17 - 2nd stage control differential (Hysteresis) (F08 = 0 or 1):

This is the temperature difference (hysteresis) between turning the cooling (or heating) ON and OFF.

#### F18 - Delay to turn on the 2nd stage output (F08 = 0.1 or 2):

This is the minimum time during which the 2nd stage output remains off, i.e., the time interval between the last stop and next start. This delay also happens when the device is started-up. This function can be turned off by setting it at the minimum value 0 [no].

**Note:** If the 2nd stage is set as cyclic timer (F08=2), this delay will only occur at the device start-up.

#### F19 - Alarm inhibition time when connecting the controller (F08=3 or 4):

This function is used to inhibit the alarm for a period of time when the system has not yet reached the operating temperature.

This function can be switched off by setting it at the minimum value 0 [no].

#### F20 - Enable buzzer (0-Disabled/1-Enabled):

Allows enabling and disabling of the internal buzzer for alarm signaling.

#### F21 - Status of outputs with damaged sensor:

If a sensor short circuits, is turned off, or is off the measurement range, the output takes the status set in this function.

[0] - Output off

[1] - Output on

[2] - Cycling according to times defined in [F22] and [F23]

**Note:** Function available for thermostat only, not valid for cyclic timer. If it is in heating and/or alarm mode and/or has a malfunctioning sensor, the output will turn off.

#### F22 - Output-on time in the event of error:

#### F23 - Output-off time in the event of error:

These define the minimum time during which the output will remain on/off, respectively, if the sensor is turned off, or is off the measurement range.

#### F24 - Minimum working voltage (protection):

#### F25 - Maximum working voltage (protection):

If the voltage value exceeds the limits set in these functions, the outputs will be turned off and the voltage indicator LED will flash.

To disable voltage monitoring, set [F24] greater than [F25].

#### F26 - Time for voltage validation out of range:

This time prevents slight variations in voltage from abruptly exiting the outputs. The outputs will be switched off after the voltage exceeds the limits of the working voltage and this time has elapsed. When the voltage returns to acceptable levels, the outputs will be restarted after this time.

#### F27 - Voltage offset:

It compensates for possible deviations in the reading of the mains voltage.

#### F28 - Preferred indication:

This function allows you to set the preferred measurement indication.

You can choose between:

[0] - Displays the temperature

[1] - Displays the voltage

[2] - Displays temperature and voltage alternately

**Note:** If voltage monitoring is disabled, the preferred indication is only temperature.

**F29- Digital input mode of operation:**

It allows to choose in which outputs the digital input will act.

- 0] - Disabled
- 1] - Acts only in the 1st stage (contact NA)
- 2] - Acts only in the 2nd stage (contact NA)
- 3] - It operates in both stages (contact NA)
- 4] - Acts only in the 1st stage (NF contact)
- 5] - Acts only in the 2nd stage (NF contact)
- 6] - Acts in both stages (contact NF)

The digital input allows the use of an external device to protect the control outputs (door switch or safety switch, for example). In the event of an external alarm, the corresponding output is switched off and **ALd** is displayed.

**F30 - Digital filter intensity applied to the sensor:**

This filter has the purpose of simulating increase in thermal mass at the sensor thereby increasing its response time (thermal inertia). The higher the value set in this function, the more time the sensor takes to respond.

This function can be switched off by setting it at the minimum value 0 **00**.

**F31 - Functions Lockdown:**

This enables and configures the functions lockdown:

- 0] - Does not enable the functions lockdown.
- 1] - Enables a partial lock where the control functions will be locked but the adjustment of the setpoint, process times, cyclic timer times and visualization of the maximum and minimum record are allowed.
- 2] - Enables a total lock, only displaying the time of the cyclic timer and the record of maximum and minimum temperatures.

**F32 - Time for functions lockdown:**

Allow lockdown of control functions (see item 8.3.2).

**15** - **60**] Defines the time in seconds for the controller to activate.

**F33 - Control functions shutdown:**

Enables control functions shutdown (refer to item 8.3.3).

- 0] - Disables control functions shutdown.
- 1] - Enables activation/deactivation of the control functions only if the functions are unlocked.
- 2] - Enables activation/deactivation of the control functions even if the functions are locked.
- 3] - Enables activation/disable control functions only if functions are unlocked by turning the display off.
- 4] - Enables activation/disable control functions even if functions are locked by turning the display off.

**F34 - Address of the instrument on the RS-485 network:**

Address of the instrument on the network for communication with the Sitrad software.

**Note:** In the same network there can not be more than one instrument with the same address.

**9. SIGNALS**

<b>Err 1</b>	Error in sensor: Sensor disconnected or damaged.
<b>Er-U</b>	Error in voltage measurement.
<b>ALLo</b>	Low temperature alarm.
<b>ALHi</b>	High temperature alarm.
<b>ALdi</b>	Buzzer inhibited.
<b>in ib</b>	Digital input alarm.
<b>ton</b>	Cyclic time on.
<b>toFF</b>	Cyclic time off.
<b>LOC On</b>	Functions lockdown.
<b>LOC OFF</b>	Unlocking of functions.
<b>OFF</b>	Control functions off.
<b>ECAL</b>	Contact Full Gauge Controls.
<b>PPPP</b>	Reconfigure the values of the functions.

**10. GLOSSARY OF ACRONYMS**

- °C: Temperature in Celsius degrees.
- °F: Temperature in Fahrenheit degrees.
- Heat.: Heating.
- LOC: Blocked.
- OFF: Turned off/disabled.
- ON: Turned on, enabled.
- Refr: Refrigeration.
- SET (as in "Setting") (setting or configuration).
- Vac: Electrical voltage (volts) of alternating current.

**Ecace protective cover**

It is recommended for the Evolution line, keeps water from entering the back part of the instrument. It also protects the product when the installation site is washed.

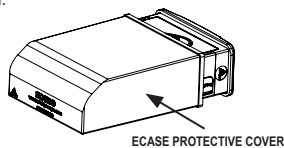

**Extended frame**

It allows the installation of Evolution line controllers with sizes 76 x 34 x 77 mm in various situations, since it does not require precision in the notch of the instrument fitting panel. The frame integrates two switches of 10 Amperes that may be used to actuate interior light, air curtain, fan, and others.

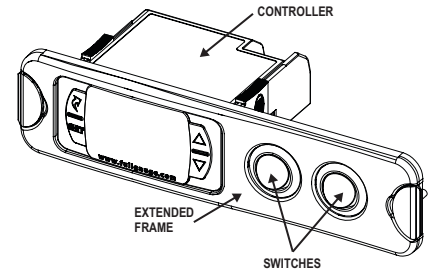

**EasyProg - version 2 or higher**

It is an accessory that has as its main function to store the parameters of the controllers. At any time, you can load new parameters of a controller and download them on a production line (of the same controller), for example.

It has three types of connections to load or unload the parameters:

- **Serial RS-485:** It connects via RS-485 network to the controller (only for controllers that have RS-485).
- **USB:** it can be connected to the computer via the USB port, using Sitrad's Recipe Editor.
- **Serial TTL:** The controller can be connected directly to EasyProg by the TTL Serial connection.

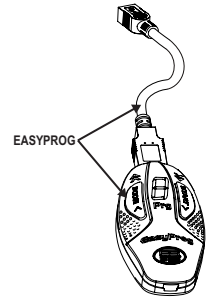

**12. ANNEXES - Reference Images**

**Image III**

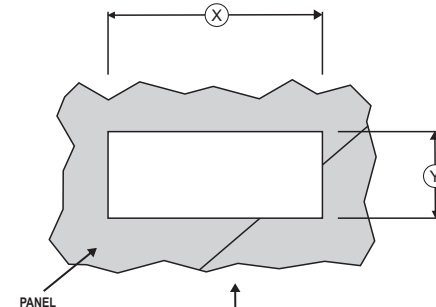

**Image IV**

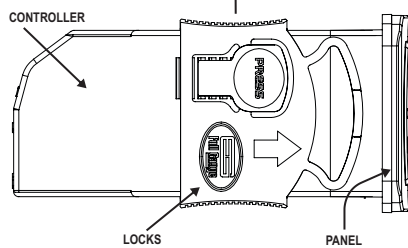

**Image V**

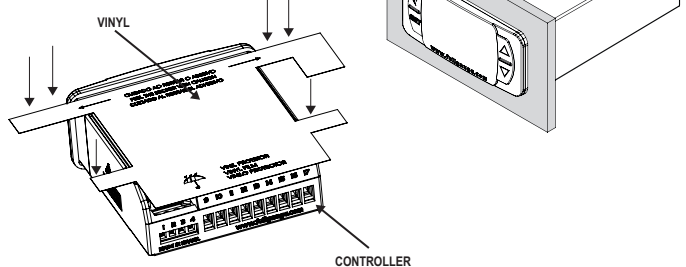



#### ENVIRONMENTAL INFORMATION

##### Packaging:

The materials used in the packaging of Full Gauge products are 100% recyclable. Try to perform disposal through specialized recyclers.

##### Product:

The components used in Full Gauge controllers can be recycled and reused if disassembled by specialized companies.

##### Disposal:

Do not incinerate or dispose the controllers that have reached the end of their service as household garbage. Observe the laws in your area regarding disposal of electronic waste. If in doubt, please contact Full Gauge Controls.

#### WARRANTY - FULL GAUGE CONTROLS

Products manufactured by Full Gauge Controls, as of May 2005, have a two (02) year warranty, as of the date of the consigned sale, as stated on the invoice. They are guaranteed against manufacturing defects that make them unsuitable or inadequate for their intended use.

##### EXCEPTIONS TO WARRANTY

The Warranty does not cover expenses incurred for freight and/or insurance when sending products with signs of defect or faulty functioning to an authorized provider of technical support services. The following events are not covered either: natural wear and tear of parts; external damage caused by falls or inadequate packaging of products.

##### LOSS OF WARRANTY

Products will automatically lose its warranty in the following cases:

- The instructions for assembly and use found in the technical description and installation procedures in Standard IEC60364 are not obeyed;
- The product is submitted to conditions beyond the limits specified in its technical description;
- The product is violated or repaired by any person not a member of the technical team of Full Gauge Controls;
- Damage has been caused by a fall, blow and/or impact, infiltration of water, overload and/or atmospheric discharge.

##### USE OF WARRANTY

To make use of the warranty, customers must send the properly packaged product to Full Gauge Controls together with the invoice or receipt for the corresponding purchase. As much information as possible in relation to the issue detected must be sent to facilitate analysis, testing and execution of the service.

These procedures and any maintenance of the product may only be provided by Full Gauge Controls Technical Support services in the company's headquarters at Rua Júlio de Castilhos, 250 - CEP 92120-030 - Canoas - Rio Grande do Sul - Brasil

Rev. 03

©Copyright 2023 • Full Gauge Controls® • All rights reserved.