



PWR-3200 plus

THREE-PHASE CONTROLLER FOR DEMAND AND POWER FACTOR



PWR32001-05T-11853

1 - DESCRIPTION

The **PWR-3200 plus** is a controller equipped with 32 outputs, configurable between demand control, power factor control, outputs for programming "schedule of events" and two alarms. The equipment is able to measure, display to the user and store in an internal data logger several electrical parameters, such as single-phase voltages and line currents, the currents of each phase, the power, demands and single-phase and three-phase power factor, the grid frequency, as well as single-phase and three-phase active, reactive and apparent energy. From the measured demands and power factors, the equipment operates with capacitor banks to correct the power factor, and with the consumer's energy loads, to control the demand of the electrical system.

2 - APPLICATION

This equipment may be used in any business, which is a consumer of electricity, and wants to manage demand or the power factor, or simply acquire knowledge about electrical parameters, for monitoring and decision-making.

3 - TECHNICAL SPECIFICATIONS

- **Supply:** 90 ~ 264 Vac ± 10% (50/60Hz)
- **Voltage Range:** 50 to 500Vac (50/60Hz)
- **Current Range:** 5A (expandable with an external CT)
- **Command:** Alarms: Two relays N.C. (3A Max)
Control Outputs: 30 x N.O. solid state relays (20~250Vac / max 125mA)**
- **Dimensions (WxHxD):** 220x134x54mm
- **Operating temperature:** 0 to 40° C
- **Operating humidity:** 10 to 90% RH (no condensation)

**Solid state relays can only drive AC voltages (VAC) loads

4 - KEYBOARD

Five keys are available for operating the menu. In general, these keys have the following functions:



✓ If the variable shown is editable, pressing this key will cause it to blink and values can then be increased or decreased. If a variable being edited (is blinking), pressing this key will validate it with the value chosen. If no editable value is shown, and the menu shows another level (represented by the symbol >>>, or by a numeric index), by pressing this key, you will go to the next menu level. Ex.:

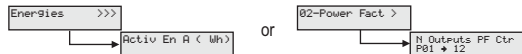

X If any variable is being edited (blinking) and this key is pressed, the editing will be canceled, and the value of the variable will remain as before the editing. If there is a previous level and this key is pressed, the menu will go back one level

+ If a variable is being edited, this key will increase the displayed value (the value that is blinking). If no variable is blinking, this key allows one to advance in the items on the same menu level. If you are in the "quick view of the electrical parameters" menu, pressing this key for 1 second will display the menu "record of maximums and minimums." Whilst in the menu "record of maximums and minimums," holding this key for 2 seconds, will reset the recorded maximum and minimum values.

Note: The increment in the speed of the variable being edited increases with the time the key is pressed.

- If any variable is being edited, this key decreases the value shown (value that is blinking). If no variable is blinking, this key allows one to return the items on the same menu level (e.g. Quit menu 2.2 and go to 2.1). If you are in the "quick view of the electrical parameters" menu, pressing the key for more than 1 second will display the menu "view electrical parameters," where the key **+** does not go to the "record maximums and minimums" menu, but goes forward in the menu items.

Note: The increment in the speed of the variable being edited increases with the time the key is pressed.

MENU If you are in "quick view of the electrical parameters" menu, clicking on the "menu" key will show the "quick access menu." If the menu is in the "Setting the priority of load shutdown" or "Set the timing for the reconnection of the loads" position, when you press this key for 2 seconds, you can edit the name of the outputs. After editing, to confirm the allocated name, you must press the key again for 2 seconds.

5 - MENUS

5.1 - Quick View of measured electrical parameters

It is used to display the selected electrical parameters. To access: go to the main menu, which will be shown when you leave another menu (e.g. from item 3 of the parameters configuration menu, and pressing the **X** key).
Note: The values shown on next screens are merely illustrative

Energies >>>	Power	
	Activ En A (kWh)	Single-phase active power
	2.941	
	Activ En B (kWh)	
	2.925	
	Activ En C (kWh)	Three-phase active power
	2.935	
	Activ En 3#(kWh)	
	8.801	
	Rt En A (kVArh)	Single-phase reactive power
	1.216	
	Rt En B (kVArh)	
	1.245	
	Rt En C (kVArh)	Three-phase reactive power
	1.198	
	Rt En 3#(kVArh)	
	3.659	
	AP En A (kVAh)	Single-phase apparent power
	3.138	
	AP En B (kVAh)	
	3.245	
	AP En C (kVAh)	Three-phase apparent power
	3.148	
	AP En 3#(kVAh)	
	9.531	

UAB	UBC	UCA	
311	309	312	Line voltages
Frequency (Hz)			
60.0			
Grid Frequency			
PF(3#) Dem(3#)			
0.92(i) 44.411			
Power factor and three-phase demand			
PF iii A0.91			
B0.92 C0.92			
Single-phase power factor			
Dem(kW) A14.312			
B15.265 C14.834			
Single-phase demand			
Pow 3# P49.226			
Q20.970 S53.507			
Active, reactive and apparent three-phase power			
S(kVA) A17.659			
B17.874 C17.974			
Single-phase apparent power			
Q(kVAh) A6.921			
B7.005 C7.044			
Single-phase reactive power			
P(kWh) A16.246			
B16.444 C16.536			
Single-phase active power			
Cur(A) A81.233			
B81.546 C81.224			
Currents in each phase			
Vo1(V) A220.1			
B219.2 C221.3			
Phase voltages			

The "iii" or "i" means that the power factor is inductive. If it would be capacitive, the letter shown would be "c".

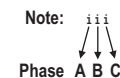

5.2 - Visualize Electrical Parameters

The same as "Quick View of Electrical Parameters" (the screen menus are the same), but differs from the **+** key, this does not go to the maximum and minimum menu, but advances in the menu items.

To access: From within the "Quick View of Electrical Quantities" menu, press the **-** key for 2 seconds.

Note: After 2 minutes without touching any key, the menu automatically returns to quick view of the measured electrical parameters.

5.3 - Record of Maximums and Minimums

This menu shows the maximum and minimum values of some parameters.

To access: From within the "Quick View of Electrical Parameters" menu, press the **+** key for 2 seconds.

Note: From within this menu, pressing the **+** key for more than 2 seconds to reset all the recorded values.

MM1- Max dem req	
Phase A 00.0 kW	Maximum single-phase demand
MM2- Max Urms	
Phase A 00.0 U	Maximum voltage of phase
MM3- Min Urms	
Phase A 00.0 U	Minimum voltage of phase
MM4- Max Irms	
Phase A 00.0 A	Maximum current
MM5- Min ind PF	
3# 1.00	Minimum recorded inductive Power Factor (PF)
MM6- Min cap PF	
3# 1.00	Minimum recorded capacitive Power Factor (PF)

5.4 - Parameters Configurations

This menu is subdivided into eight sub-menus for the configuration of all the controllers' parameters. To access: being in the "Quick View of Electrical Parameters" menu, press the **+** and **-** keys at the same time.

Note: To configure parameters, whenever entering this menu, you must first enter the code "123", in menu 1 (Access Code).

After insert the code, you must wait until shows the message "Right Code" or "Wrong Code", then browser through other menus.

01-Access Code — Access code

Other menus are available below

5.5 - Facilitated Access Menu

Menu facilitating the quick configuration of some parameters.

To access: in the menu "Quick View of Electrical Parameters", press the **MENU** button.

N Outputs PF Ctr P01 → 12	Number of outputs to control the PF
N Outputs Dem Ct D01 → 12	Number of outputs for demand control
Rewrite mem L03 → YES	Rewriting Memory
Activate DL L05 → YES	Enable the data logger
Clear Memory ? F03 → NO.	Clear Memory
Clock R01 → 12:00:00	Set the time
Date R02 → 01/01/2010	Set the date
Week day R03 → SUNDAY	Set the day of the week
Init screen C06 → VOLTAGE	Setup of initial screen

5.6 - Error Codes

Whenever an error is recognized by the controller, a message will be displayed, appearing alternately with the menu that is being displayed.

The eight errors that can occur, which are described in Table 1, are shown by the controller as numbers, as the following example shows:

OPERATION ERROR
123---78

In the example, the controller is indicating that 1,2,3,7 and 8 are in error status. 4,5 and 6 are NOT in error status, and therefore in place of the numbers there is a "-". But, if instead of this symbol there was a number, it would indicate an error. Likewise, if instead of the 8 there was a "-", item 8 would not be in error status.

Error code	Error Description
1	Voltage limit of phase A out of range
2	Voltage limit of phase B out of range
3	Voltage limit of phase C out of range
4	Current limit of phase A out of range
5	Current limit of phase B out of range
6	Current limit of phase C out of range
7	Sequence error of the voltage phases
8	Unparameterized Controller

Table 1: Error codes

6 - POWER FACTOR (PF)

The power factor is the relationship between active power and apparent power of an electrical system. In addition, as the harmonics influence the value of these powers, they should be considered in the calculations. This device takes into account the harmonics.

The control of the power factor is achieved by inserting and removing capacitor banks in parallel with the electrical grid.

In general, when motors are turned on, the power factor tends to be lower for the inductive side; because of this, capacitors should be placed in parallel. When the motors are turned off, the power factor tends to be less inductive and if the capacitor banks are activated, this may be capacitive.

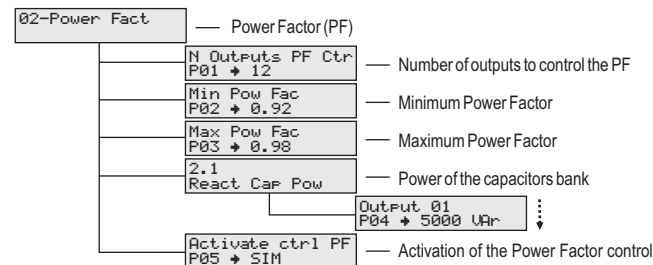

6.1 - Configurations for the control of the power factor

6.1.1 - Outputs

The User can select the number of outputs for the power factor control; this can be between 0 and 32 (none or all outputs). This parameter can be edited in menu "N Outputs PF Ctr".

The outputs for the control of the power factor always start at the first output, i.e., "OUT-01" will always be the first output for this control. The other outputs are next, in ascending order.

Note: To change the number of outputs for the Power Factor or Demand control, the controls must be disabled. If not, you cannot change the alteration. CAUTION, any output that is activated will be deactivated. In other words, all outputs will be reset.

6.1.2 - Reference values for the control

In the "Min Pow Fac" menu the value of the minimum desired power factor, can be edited, this is the reference value where the power factor is low; the capacitor banks may be inserted. In the menu "Max Pow Fac", the maximum power factor value desired can be edited, which is the reference value when the power factor is too high, the capacitor banks may be removed.

6.1.3 - Information on reactive power of the installed capacitor banks

To control the power factor, the controller needs to know the capacitive reactive power (kVAR) of each capacitor bank installed on each output. This helps the controller to insert or remove the right amount of capacitors to correct the power factor.

The value can be edited in the sub-menu "React Cap Pow", and the values are in VAR (Volt Ampere Reactive). Therefore, if the informed value is 1kVAR, for example, you should enter the value 1000.

If no reactive power value is associated with an output (i.e. it is at zero), this output will not be used to control the power factor.

6.1.4 - Enabling the power factor control

Control of the power factor can be enabled or disabled in menu "Activate ctrl PF", by selecting "YES" to activate the control, and "NO" to disable it. When activated, the control operates every 30 seconds, and can activate or deactivate more than one capacitor bank at a time.

7 - DEMAND

Demand: average of the active or reactive electrical power, requested for the installed electrical system by the installed load operating in the consumers unit, during a specified time interval.

Annexed to this manual are some case examples..

For finer control, the **PWR-3200 plus** works by disconnecting and reconnecting loads (when necessary) every 30 seconds.

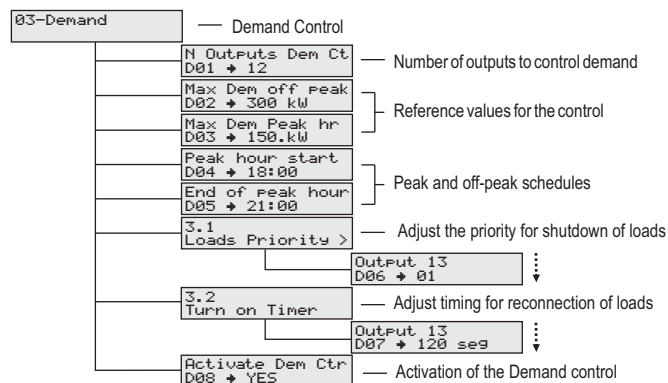

7.1 - Demand Control settings

7.1.1 - Outputs

The number of outputs to control the demand is selected by the User, this figure may be between 0 and 32 (none or all outputs). This parameter is edited in item 3.1.

The outputs to control the demand always begin at the first output after the last power factor control. The other outputs are next, in ascending order. Therefore, there can only be 32 outs to control demand, if there is none allocated for the power factor control. If for example, 12 outputs are for controlling the power factor, 20 at the most could be used to control demand.

See note on item 6.1.1.

7.1.2 - Reference valued for the control

In menu "Dem Max For a Pta" the reference value of the maximum demand in the "off-peak period" can be changed. This value is the reference for the control demand (kWatts), as from 5% less this value, the loads will start to be turned off, in the order (priority) that has been defined.

In menu "Max Dem Peak hr" a value can be configured, which works exactly in same way as described above, differing from that amount will be assumed to be the "peak periods."

Note 1: There may be a fine for exceeding the demand as read by the utility meter if this exceeds the contracted value by 5%. It is up to the user whether or not to include this tolerance as the reference value.

Note 2: As the integration period for the demand calculation of the PWR-3200 plus, may not be synchronized with the utility meter (the start of the 15 minutes to calculate the demand may not occur at the same time) it is wise to provide a margin (5 or 10% below the value of contracted demand) to have tolerance.

7.1.3 - Definition of Peak periods and Off-peak periods

In the D04 parameter it is possible to set the time in which the "off-peak period" begins. It will finish in the value set in parameter D5.

The parameter settings D5, allows the adjustment of the time that the "peak period" ends. At this time will be starting "off-peak period"

7.1.4 - Setting priorities and shutdown of loads

In the sub items of 3.1 menu (Loads Priority), the priority shutdown of loads is configured, this is used by the device to control demand.

The priority indicates, in ascending order, the order in which the loads are disconnected, and cannot be repeated for more than one load. For example, if the first output to control the demand is "Output 13" (out-13), and the priority is 1, this will be the first to be turned off. If the priority was 5, it would be the fifth to be turned off. If there is an attempt to allocate a priority that has already been assigned to another output, a priority repeated warning will be issued, and the value will remain as zero (meaning no priority).

If an output has no priority defined (is set at zero), it will not be used to control demand.

To use a priority that is being used, remove it from the output that is being used (assigning priority zero), then use it in the desired output.

Also in this menu, the names of the outputs can be changed. To do this, go to the desired output, and press the **MENU** key for 2 seconds. When you see "-----", use the **+** or **-** keys to select the letter. To move to the next letter, you must press **✓**. At the end of the edition, to confirm the edited name, press the **MENU** key, until "OK!" is shown.

7.1.5 - Setting the times for load reconnection

After a load is disconnected, it becomes ready to be reconnected, with the same priority in which it was disconnected. However, you must assign a minimum period for this load that was disconnected to remain off. In other words, if output 13 was shut down, and this output has a time set at 120 seconds (2 minutes) only after a period of 2 minutes can it be reconnected. If the set time for the output is zero, then the next control load action can be reconnected, if applicable. Adding in such a way that from the disconnection the timer counter will start measuring the time, if the set value is 30 seconds, this would be the same as leaving it at zero, because in the next demand control (30 seconds later), this output would already be enabled.

The timer setting of each output can be edited in the sub items of menu 3.2 (Turn on Timer), and the value shown is expressed in seconds.

As in "Set the shutdown priority of the loads," this menu also permits the editing of the name of outputs, as previously described.

7.1.6 - Activation of demand control

The demand control can be enabled or disabled in the D08 parameter, by selecting "YES" to activate the control, and "NO" to disable it. When activated, the control operates every 30 seconds and is 15 seconds out of phase from the power factor control.

8 - DATA LOGGER

The PWR-3200 plus has an internal memory (data logger) with a capacity of 8 Mbits, and it is used to periodically store the electrical and control information about the equipment.

04-Data Logger		Data logger Configuration
Sample time	L01 → 20.sec	Time between samples
Volt variation	L02 → 18.V	Voltage Variation
Rewrite mem	L03 → YES	Overwrite memory
Operation Mode	L04 → Manual	Operating Mode
Activate DL	L05 → YES	Enable data logger

8.1 - Time between samples

In the L01 parameter of the parameters configuration menu, the timing between the sampling of the information in the data logger may be edited. The configured value is in seconds.

8.2 - Voltage Variation

If there is a need to enforce the storage in the data logger, by way of a voltage variation seen in each phase of the grid, this variation can be configured in the L02 parameter. If the value is set to 10 volts, for example, an increase in any voltage of more than 10 volts will cause the device to register this information in the data logger instantaneously.

8.3 - Overwrite memory

If the memory is full with data storage, the User can choose, from parameter L03, if he wants to overwrite the memory from the beginning, overwriting the old data, or if there is no need to store any information.

8.4 - Operation Mode

This option offers protection against the activation, or deactivation, of the data logger in the easy access menu, it operates in the following way: if the option "Always OFF" is activated, the data logger cannot be activated from anywhere. If the option selected is "Always ON", the data logger cannot be disabled. If it is set to "MANUAL", the operator can enable or disable the data logger both from within the easy access menu, and in the advanced settings menu.

8.5 - Enable the data logger

Enable or disable the data logger.

9 - EVENTS SCHEDULER

The PWR-3200 plus has up to six outputs, which can be programmed to turn on and off at certain times of any day of the week. The number of outputs for the events schedule is determined by the other outputs, which are not allocated to the power factor control, demand control or alarms. That is, if the 12 power factor outputs, 12 for demand, and two for alarms are all allocated, there will be exactly six outputs per schedule of events (32-12-12-2=6). In this case, if the device had 13 outputs per power factor control and 13 for demand control, for example, there would be outputs for the events scheduler (32-13-13-2=4).

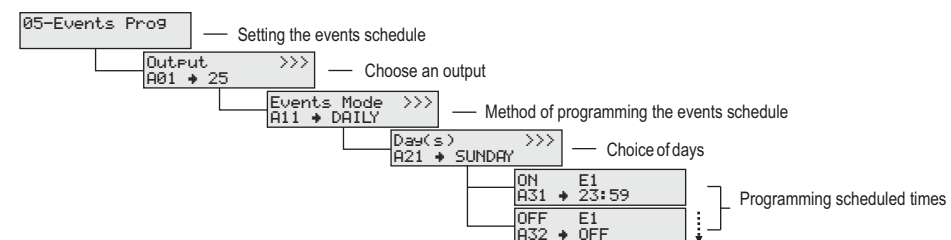

9.1 - Choice of Output

On the A01 parameter the controller output can be selected, which will program the start and stop time.

When you select the output, the program automatically goes to the "A11", for the choice of "Operational Mode."

9.2 - Events Scheduler Programming Mode

With this option, you must choose the way the programming will be done, according to the following:

- Daily Schedule: In this mode, the User can choose any one of the seven days of the week, to set the timed events.
- Work day schedule: In this mode, the User may choose to configure the events schedule for Sunday to Saturday, and/or from Monday to Friday. With the latter option, the User sets the events schedule for Monday, and they will be replicated for the other days of the week.
- Weekly schedule: In this mode, the User may choose to configure the hourly scheduled of events for all days of the week. This means, by setting the events for Sunday, they will be replicated for all other days of the week.

Care should be taken when altering this option, because when making a change, all hourly scheduled events times will be erased.

9.3 - Selection of the days

As previously explained in section 9.2, you can choose the days according to the selected programming mode. That is, if the "daily schedule" mode has been selected you can choose any day of the week. In "work day schedule", you can choose Sunday, Monday to Friday, and/or Saturday. In the "weekly programming", the only option is the Sunday to Saturday.

9.4 - Programming timed events

After selecting the output, the programming mode and the day or days, you can configure up to events to connect the output, and events to turn it off, as indicated by E1, E2, E3 and E4.

All the "connect" events leave the factory with the time set to 11:59 pm and the "disconnect" events set to "OFF". Whenever the event is set to "OFF", the value of the corresponding "connect" event is ignored (the output is not turned on). If the "disconnect" event is different to "OFF", the output will be connected at the time set in the "connect" event, and turned off at the time set in the "disconnect" event. If it is desired that the output is turned on on a certain day (Monday, for example), crosses midnight, and is turned off only during the next day (Tuesday in this case), one should place the "disconnect" event in "CROSS" (after 11:59 pm), and also the "connect" event of the next day at 00:00. The output will then only be turned off at the time of the "disconnect" event, the next day (in the example, Tuesday). If the event "disconnect" is set to "CROSS", but there is no "connect" event the next day at 00:00, or all "disconnect" events are set to "OFF", then the output is disconnected.

10 - SETTING THE CLOCK AND DATE

On the R01, R02 e R03 parameters of the menu, you can set the time, date and day of week, respectively. The time setting is done by increasing, or decreasing minutes, which consequently will also set the time. Seconds are not adjusted, but when the time setting is confirmed, they are zeroed.

The date is adjusted by the increasing or decreasing the days, which will consequently change the month (the months change after the 31st day) and year (the year changes after the 12th month). The internal clock has a calendar set for leap years, and the number of days in any month, and it will progressively show the date correctly. However, when editing the date, it is possible to insert an invalid value, such as February 31. **The User should take all precautions to avoid this.** The day of the week is chosen by selecting from Sunday to Saturday.

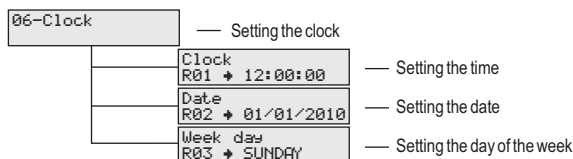

11 - OTHER SETTINGS

Other configurations for the device, relating to other tasks, are located in the sub-item of menu 7.

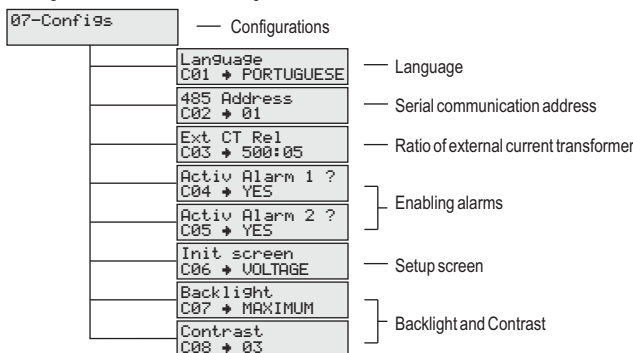

11.1 - Language

In the C01 parameter, you can select the device menu language. The options are - Portuguese, English and Spanish.

11.2 - Serial Communication Address

In the C02 parameter it is possible to change the address of the RS485 serial communication. The number must be unique in the network, and at most 247.

11.3 - Ratio of external current transformer

In the C03 parameter you can change the ratio of external current transformer (CT). The minimum value is 5:5 (without an external CT), and the maximum is 3000:5 (i.e., when 3000 Amps pass through the cabling, there will be 5 amps at the output of the CT).

Care should be taken when setting this value, since all the calculations and electrical information that the device offers are dependent on this.

11.4 - Activating the alarm

The C04 and C05 parameters allow the outputs 31 and 32 to be configured for alarms of Power Factor and Demand, respectively. The choice between them is independent, and if you configure "NO", the output can be used to control power factor, demand control, or if nothing is allocated to any of these controls it will be an "events scheduler".

The Alarms take precedence over the scheduled event outputs, i.e., if outputs 31 and 32 are allocated to the schedule, and alarm 1 and/or 2 become activated, the output no longer functions as a schedule, it becomes an alarm function.

Operation: When an alarm occurs, the output 31 will be triggered intermittently (on and off every second), if it is a PF, or the output 32, if the event is to control demand. The alarms are deactivated by pressing the **MENU** button, returning again when an error occurs again.

11.5 - Setting up the initial screen

When setting up the C06, you will be informing the device which screen to show after being idle for 15 seconds, if you are in the menus "configuration parameters," "visualization of maximums and minimums" or "quick access" or for 2 minutes, if you are in the "visualization of electrical parameters." For example, if the configuration of the "initial screen" is set at "current" (CORR) and the unit has been idle for 15 seconds in somewhere in the "configuration parameters" menu, the display screen will automatically return to where you are for the "quick view of electrical parameters," showing the currents.

11.6 - Backlight e Contrast

In the C07 parameter the device display backlight can be adjusted. The backlight is the brightness of the screen, and can choose between Maximum, High, Medium, Low and MINIMUM.

In the C08 parameter it is possible to configure the display contrast, which will adjust the brightness of the letters that are shown.

12 - FUNCTIONS

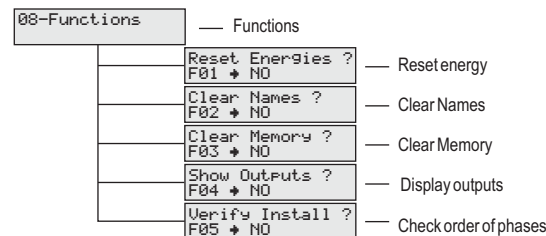

12.1 - Reset Power

The active, reactive and apparent single-phase and three-phase power are tabulated over time and are periodically stored in an E2PROM memory so that this information is not lost in the case of having to reboot the machine for some reason, or if there is a power outage and the device is powered down. When performing this function, all power is zeroed.

12.2 - Clear Names

The use of this feature causes all the names assigned to demand control outputs to be erased.

12.3 - Clear Memory

This function causes all the data logger memory to be erased.

12.4 - Display Outputs

This may become a little confused in relation to which outputs control the power factor, which ones are for the demand control, which are to schedule events, and which ones are for the alarms, this feature helps to make this a little clearer, since it indicates, through a display screen and LEDs, that shows which outputs belong to each function.

12.5 - Check order of the phases

This function must be performed after the installation of the device to make sure that it is correctly installed. If it is correct, an "OK" will be displayed, however, if not, there will be an error warning, and the unit will indicate the phases with these errors.

Because many electrical installations do not have all phases shown, this function becomes necessary.

If the unit shows an error, check the following, in this order:

- Is the current in each phase greater than the "external CT ratio," divided by 20? For example, if the external CT ratio is 500:5, then the current must be greater than 5 Amps (500/5 = 100, 100/20 = 5).

- Try to invert the polarity of the current measurement of the phases that are showing errors. If only one phase is showing an error, it is quite possible that the current polarity is inverted (the effect of the inverted polarity is an indication of capacitive power factor, when it is inductive, and vice versa).

If the error continues, and for more than one phase, the voltages and currents may not be connected correctly (voltage 1 with current 1, and this applies for phases 2 and 3). One may observe the active, reactive and apparent power, so that the consistency of readings may be observed. If the reading of two of the phases is inconsistent, you should try to change their current signals, namely, the current in-CT2-IN and CT2-OUT, should go to CT3-IN and CT3-OUT, and the current in 3 goes to 2.

- If the function is showing an error but no phase is shown (all phases are zero, in the display, in the result of the function), then the error is in the voltage phase sequence. Therefore the order of phases should be reversed, B with C, A with B or C with A, for the controller to sample some of the sequences: ABC, BCA or CAB.

Note: This function works perfectly for inductive circuits. If they are capacitive, it may show unjustified errors, or not display the errors correctly.

13 - OTHER IMPORTANT INFORMATION

* The voltages as well as the current have a minimum value to be measured, so that the controller shows the information correctly. If any of the three voltages is below 50 volts (but greater than 10), the controller will show the value of 0.1 volts, and indicate "voltage limit error" in the corresponding phase. If any current is less than 10mA times the CT ratio, then the current and the powers of this phase will be shown as a zero value. For example, for a CT of 500:5, the minimum current would be 1 Amp (500/5*10mA).

* The accuracy of the instantaneous measurement of the electrical parameters is 2%. However, for power, this is 3%. These errors do not take into account the accuracy of the external current transformer, which is the responsibility of the equipment user. It is advisable to use Class 0.3 transformers.

* When a measured value exceeds one million, the unit changes from Kilo (k) to Mega (M) and when this passes one billion, it will be shown in Giga (G).

* The equipment considers, for measurements and calculations, up to the 5th harmonic for voltage and the 233rd for current.

* If the equipment loses its calibration because of some external noise, it will automatically reload the values stored in the E2PROM, and a warning will show: "Recar. Calib."

14 - TROUBLE SHOOTING

- Capacitive power factor, should be inductive - Polarity of the current sensor (CT) reversed.

Action: exchange TCx IN with TCx OUT.

- Currents and power factors show very abrupt changes - This effect is common in industrial installations, where there are machines that have large motors or are controlled by semi-conductor power devices.

- Currents and power are zeroed - The current is probably below the minimum threshold for reading.

- Voltages are zeroed, or at 0.1 volt - Voltage at zero is indicative that the voltage is below 10 volts. If at 0.1, this is indicative that it is between 50 and 10 volts.

- Power is very unbalanced - If the power is unbalanced in an uncommon manner, currents are probably not matched to their respective voltages, i.e., current sampling in the CT, at CT1 IN and CT1 OUT, is not the same as the phase 1 voltage, for example.
Action: Match the voltages, with their respective currents.
- Serial does not work - The A and B signals may be changed, the distance may be more than 1000 meters; the serial communication cables may be receiving interference because of proximity to power cables.
Action: Check if the RX and TX of the used "CONV" are blinking. Test communication with the equipment that is right next to the computer.
- Output is not operating - the common may be disconnected, the solid-state relay may have been damaged by excessive current, there may be a bad contact, or a severed cable.
Power factor control does not work - The control may be disabled, the references for the control may be unadjusted, the reactive power information from the capacitor banks may not have been correctly informed, the power factor is inductive (installation errors).
- Demand control does not work - The control may be disabled, the references to the control may be unadjusted, the information on the priorities may not have been input correctly.

15 - INSTRUMENT FIXATION MODE
15.1 - DIN mount fixation

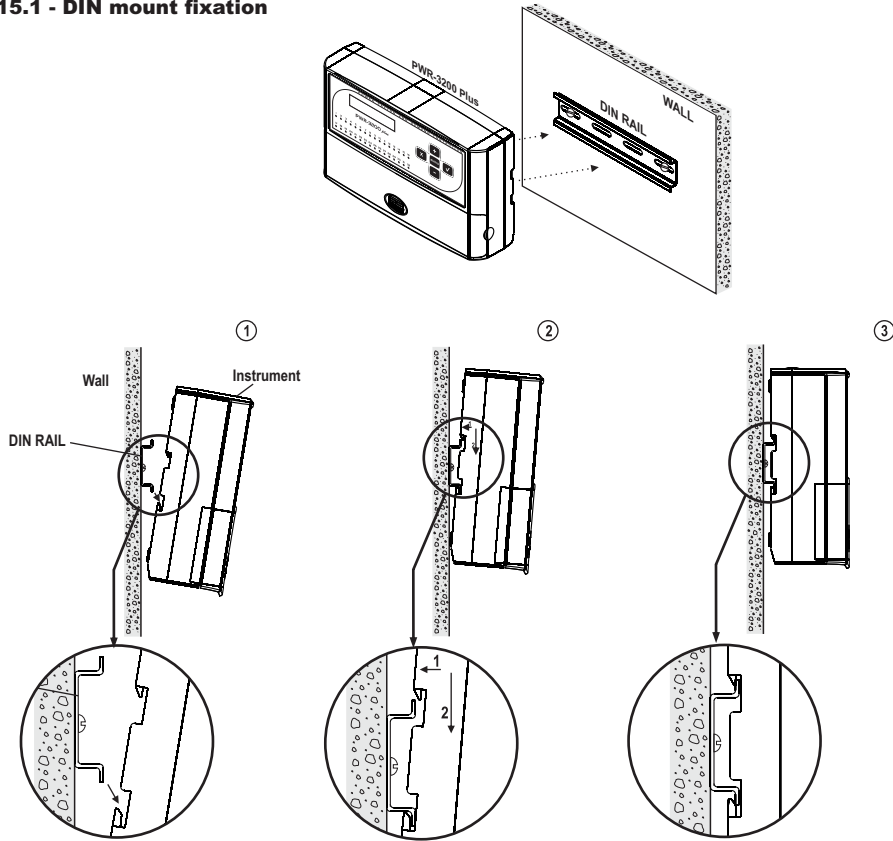

15.2 - Screw fixation (wall-mounted)

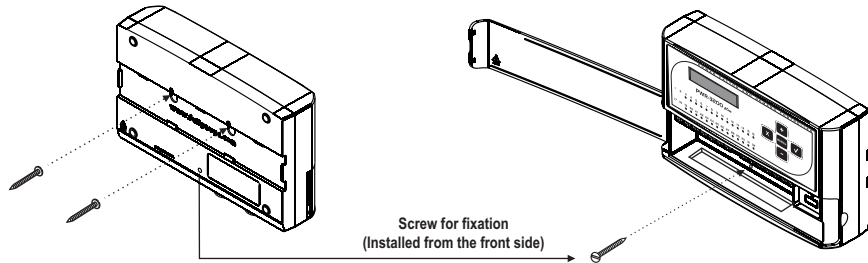

16 - WIRING DIAGRAM

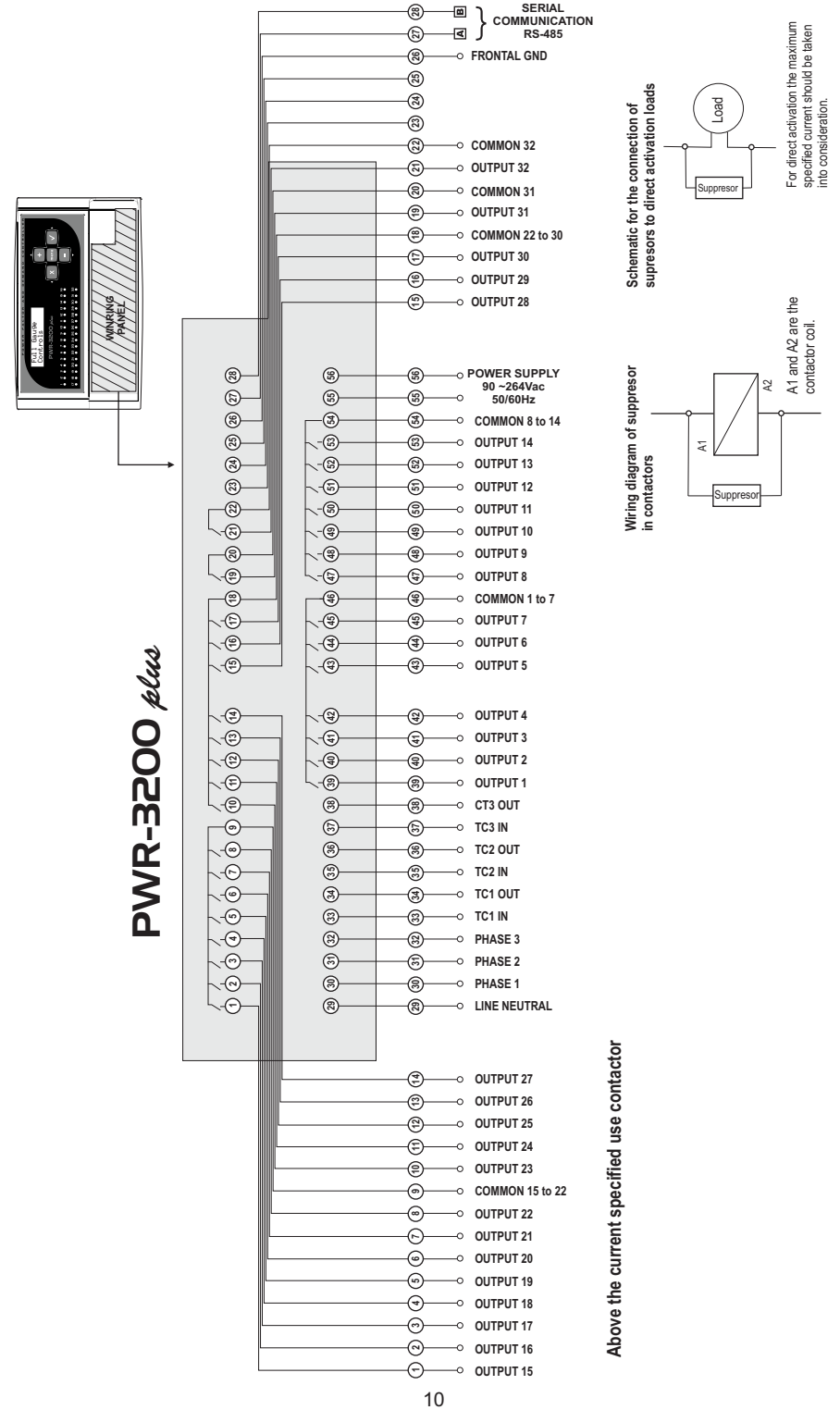

17 - SETTING THE OUTPUT FOR THE CONTROL OF THE POWER FACTOR

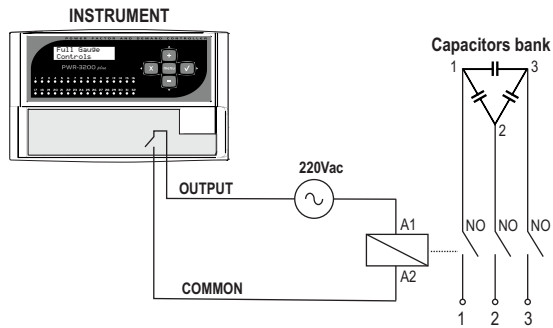

18 - SETTING THE DEMAND CONTROL OUTPUT

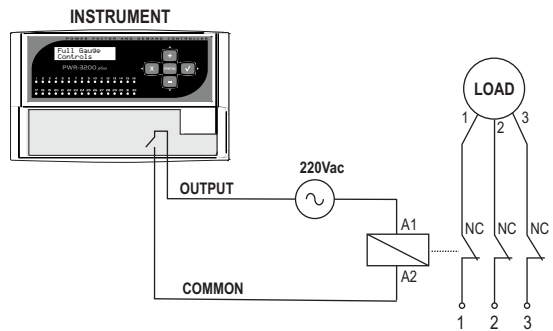

19 - SETTING OF ALTERNATIVE DEMAND CONTROL OUTPUT WITH THE NORMALLY OPEN CONTACTORS

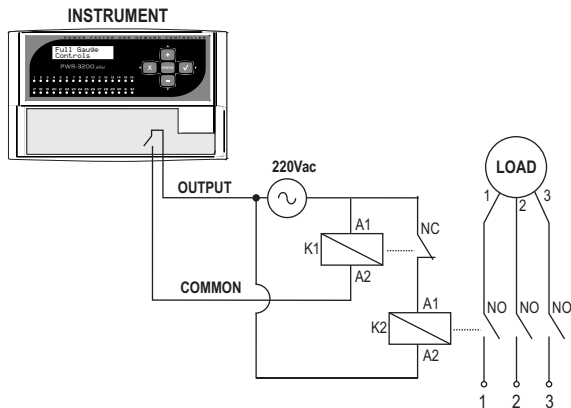

IMPORTANT

As chapters of IEC 60 364 norms:

- 1: Install protectors against over voltage on power supply
- 2: Sensor cables and computer signals can be together, however not at the same place where power supply And load drive pass for.
- 3: Install suppresor of transient (RC filters) in parallel to loads, as for to increase the useful life of the relays.

20 - INTEGRATING CONTROLLERS, RS-485 SERIAL INTERFACE AND COMPUTER

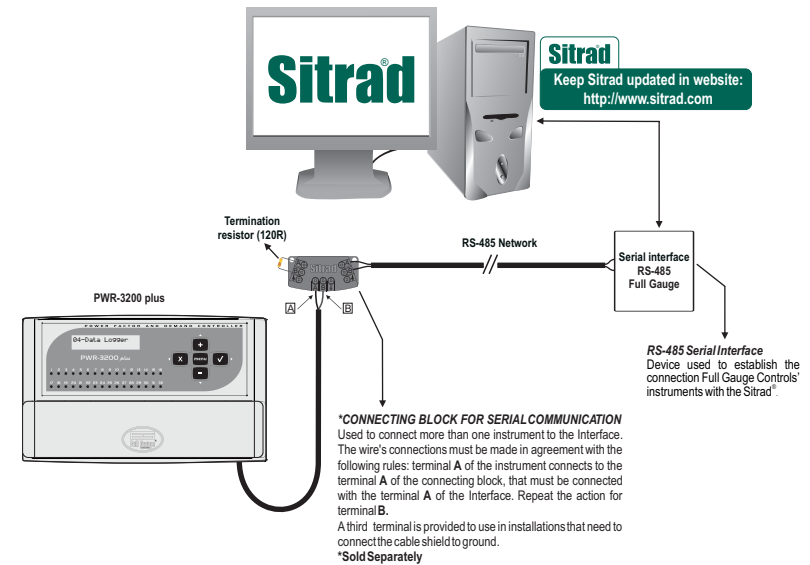

ENVIRONMENTAL INFORMATION

Package:

The packages material are 100% recyclable. Just dispose it through specialized recyclers.

Products:

The electro components of Full Gauge controllers can be recycled or reused if it is disassembled for specialized companies.

Disposal:

Do not burn or throw in domestic garbage the controllers which have reached the end-of-life. Observe the respectively law in your region concerning the environmental responsible manner of dispose its devices. In case of any doubts, contact Full Gauge controls for assistance.

21 - ANNEXES

Time	Measured power	Reference	Average	Excess / Shortage
1	15.0	32	15	49
2	20.9	32	17.9	46.1
3	21.2	32	19	45
4	28.9	32	21.4	42.5
5	31.1	32	23.4	40.6
6	38.2	32	25.8	38.1
7	43.7	32	28.4	35.6
8	45.8	32	30.6	33.4
9	36.0	32	31.2	32.8
10	26.8	32	30.7	33.3
11	21.3	32	29.9	34.1
12	21.0	32	29.1	34.8
13	13.0	32	27.9	36.1
14	18.8	32	27.2	36.7
15	19.4	32	26.7	37.3

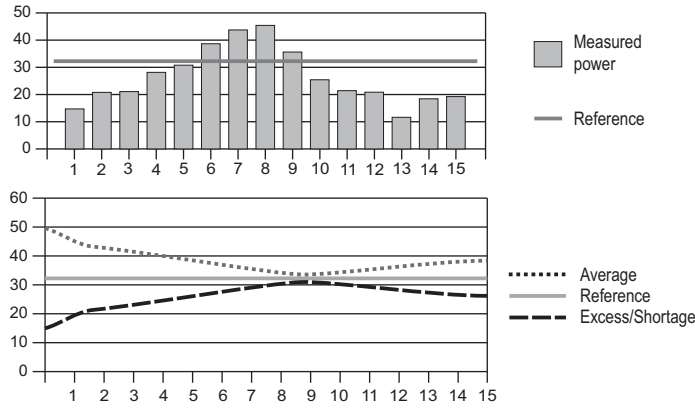

Time	Measured power	Reference	Average	Excess / Shortage
1	19	32	19	45
2	20	32	19.5	44.5
3	25	32	21.3	42.7
4	26	32	22.5	41.5
5	24	32	22.8	41.2
6	32	32	24.3	39.7
7	30	32	25.1	38.9
8	28	32	25.5	38.5
9	38	32	26.9	37.1
10	40	32	28.2	35.8
11	45	32	29.7	34.3
12	40	32	30.6	33.4
13	30	32	30.5	33.5
14	25	32	30.1	33.9
15	25	32	29.8	34.2

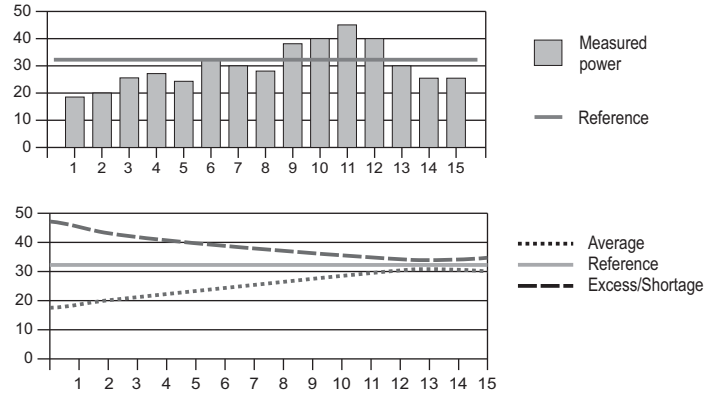

Time	Measured power	Reference	Average	Excess / Shortage
1	9	32	9	55
2	9	32	9	55
3	36	32	18	46
4	44	32	24.5	39.5
5	69	32	33.4	30.6
6	69	32	39.3	24.7
7	69	32	43.6	20.4
8	39	32	43.0	21.0
9	32	32	41.8	22.2
10	23	32	39.9	24.1
11	6	32	36.8	27.2
12	6	32	34.3	29.8
13	6	32	32.1	31.9
14	6	32	30.2	33.8
15	44	32	31.1	32.9

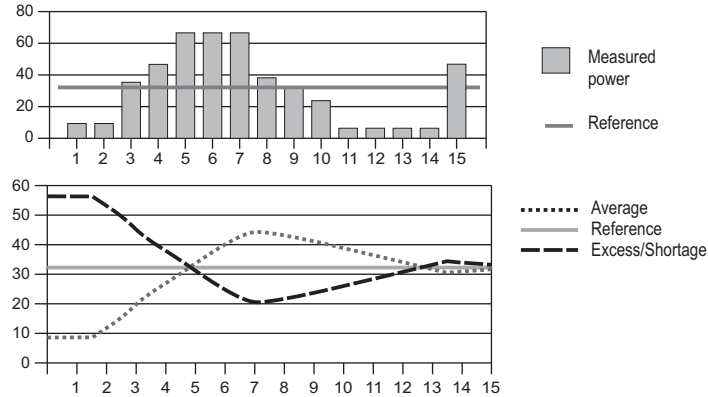

Configurable Parameters					
Parameter	Description	Minimum	Maximum	Standard	Unit
-	Access Code	0	999	0	
P01	Number of PF outputs	0	32	12	
P02	Minimum Power Factor	0.6	1	0.94	
P03	Maximum Power Factor	0.62	1	0.96	
P04	Reactive power for installed CB	0	65535	0	VAr
P05	Enable PF control	NO	YES	NO	
D01	Number of outputs for Demand	0	32	12	
D02	Max Dem Off-Peak	0	4500	0	kW
D03	Max Dem Peak	0	4500	0	kW
D04	Peak period	00:00	23:59	18:00	hh:mm
D05	Off-peak period	00:00	23:59	21:00	hh:mm
D06	Priority of disconnection of loads	1	Number of DEM outputs	0	
D07	Timing for reconnection of loads	0	43200	0	Sec.
D08	Enable DEM control	NO	YES	NO	
L01	Time between DL samples	2	43200	20	Sec.
L02	Voltage variation	2	100	10	Volts
L03	Rewriting Memory	NO	YES	NO	
L04	Operating Mode	Always OFF	Manual	Manual	
L05	Enable Data Logger	NO	YES	NO	
A01	Output number for programming schedule	Next output after the demand control	Next output after the demand control	25	
A11	Schedule Mode	Daily	Weekly	Daily	
A21	Day (s) chosen for programming	Sunday	Saturday	Sunday	
A31	Turn on event E1	00:00	23:59	23:59	hh:mm
A32	Turn off event E1	00:00	OFF	OFF	hh:mm
A33	Turn on event E2	00:00	23:59	23:59	hh:mm
A34	Turn off event E2	00:00	OFF	OFF	hh:mm
A35	Turn on event E3	00:00	23:59	23:59	hh:mm
A36	Turn off event E3	00:00	OFF	OFF	hh:mm
A37	Turn on event E4	00:00	23:59	23:59	hh:mm
A38	Turn off event E4	00:00	OFF	OFF	hh:mm
R01	Ajuste do horário	00:00	23:59	12:00	hh:mm
R02	Ajuste da data	01/02/07	01/01/30	01/01/10	dd:mm:yy
R03	Ajuste do dia da semana	Sunday	Saturday	Sunday	
C01	Language	Portuguese	Spanish	Portuguese	
C02	Address on the RS485 network	1	247	1	
C03	External CT ratio	5	3000	5	
C04	Activate alarm 1	NO	YES	NO	
C05	Activate alarm 2	NO	YES	NO	
C06	Preferential treatment	Line Voltage	Disable	OFF	
C07	Adjust backlight	Minimum	Maximum	Maximum	
C08	Adjust contrast	2	8	3	
F01	Reset the accumulated energy	NO	YES	NO	
F02	Clear names from the DEM control outputs	NO	YES	NO	
F03	Erase the Data Logger memory	NO	YES	NO	
F04	Allocation of outputs	NO	YES	NO	
F05	Verify if the installation is correct	NO	YES	NO	

Configurable Parameters				
Parameter	Description	Minimum	Maximum	Unit
Uo1<U>	Single-phase voltage	0	500	Volts
Cur<A>	Single-phase current	0	3000	Amperes
P<kW>	Single-phase active power	0	1500	Kilo Watts
Q<kVAr>	Single-phase reactive power	0	1500	Reactive Kilo Volt Ampere
S<kVA>	Single-phase apparent power	0	1500	Kilo Volt Ampere
P<3φ>	Three-phase active power	0	4500	Kilo Watts
Q<3φ>	Three-phase reactive power	0	4500	Reactive Kilo Volt Ampere
S<3φ>	Three-phase apparent power	0	4500	Kilo Volt Ampere
Dem<kW>	Single-phase power demand	0	1500	Kilo Watts
PF	Single-phase power factor	0.00	1.00	
PF<3φ>	Three-phase power factor	0.00	1.00	
Dem<3φ>	Three-phase power demand	0	4500	Kilo Watts
Frequency	Mains frequency	0	65	Hertz
Uab Ubc Uca	Line Voltages	0	866	Volts
Activ En A <kWh>	Phase A accumulated active power	0	1431655	Kilo Watt hours
Activ En B <kWh>	Phase B accumulated active power	0	1431655	Kilo Watt hours
Activ En C <kWh>	Phase C accumulated active power	0	1431655	Kilo Watt hours
Activ En 3φ<kWh>	Three-phase accumulated active power	0	4294967	Kilo Watt hours
Rt En A <kVArh>	Phase A accumulated reactive power	0	1431655	Reactive Kilo Volt Ampere hour
Rt En B <kVArh>	Phase B accumulated reactive power	0	1431655	Reactive Kilo Volt Ampere hour
Rt En C <kVArh>	Phase C accumulated reactive power	0	1431655	Reactive Kilo Volt Ampere hour
Rt En 3φ<kVArh>	Three-phase accumulated reactive power	0	4294967	Reactive Kilo Volt Ampere hour
Ap En A <kVAh>	Phase A accumulated apparent power	0	1431655	Kilo Volt Ampere hours
Ap En B <kVAh>	Phase B accumulated apparent power	0	1431655	Kilo Volt Ampere hours
Ap En C <kVAh>	Phase C accumulated apparent power	0	1431655	Kilo Volt Ampere hours
Ap En 3φ<kVAh>	Three-phase accumulated apparent power	0	4294967	Kilo Volt Ampere hours